

SPECIFICATIONS

TITLE : 9.5" TFT COLOR MODULE

NUMBER : HLD 0912-013020 REV.4 PAGE 1

HOSIDEN AND PHILIPS DISPLAY CORPORATION

HLD 0912 - 013020

9.5 INCH

**ACTIVE MATRIX COLOR
TFT DISPLAY**

640 x 480 DOTS

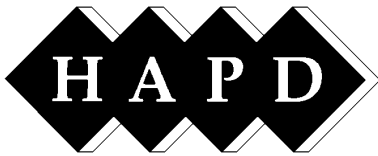

SPECIFICATIONS

TITLE : 9.5" TFT COLOR MODULE

NUMBER : HLD 0912-013020 REV.4 PAGE 2

CONTENTS

1. OUTLINE

- 1-1 Scope
- 1-2 Features
- 1-3 Block Diagram

2. ABSOLUTE MAXIMUM RATINGS

3. DISPLAY CHARACTERISTICS

- 3-1 Physical Dimensions
- 3-2 Electro-Optical Characteristics
- 3-3 Electrical Characteristics

4. DEFINITION AND MEASURING METHOD

- 4-1 Viewing Angle
- 4-2 Optical Measurement
- 4-3 Contrast Ratio
- 4-4 Response Time
- 4-5 Reflectance
- 4-6 Brightness and Brightness Uniformity
- 4-7 Supply Current

5. RELIABILITY

- 5-1 Test Item and Condition
- 5-2 Check Item and Failure Criteria
- 5-3 Functional Defects of Dots

6. APPLICABLE OTHER DOCUMENTS

7. CAUTION AND HANDLING PRECAUTION

- 7-1 Handling
- 7-2 Storage
- 7-3 Operation
- 7-4 Others

8. WARRANTY

- 8-1 Incoming Inspection
- 8-2 Warranty Period

9. OTHERS

10. DRAWING

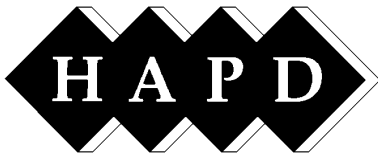

SPECIFICATIONS

1. OUTLINE

1-1 Scope

This specification shall be applied to HOSIDEN and PHILIPS Color Active Dot Matrix Liquid Crystal Display (ALCD) with CCFL backlight

1-2 Features

Display Mode	Transmissive positive type normally white mode
Display Format	640 (x3) x 480 Dots
Screen Area	197 x 149 mm
Display Outline	243,5 x 180,0 x 10,5 mm (max.)
Contrast Ratio	100:1 (min.) at 25°C
Brightness	80 cd/m ² (typ) / If = 6 mA
Response Time	Tr = 28ms (typ) / Tf = 28 ms (typ)
Color Pixel Arrangement	RGB vertical stripes
Display Surface	Low reflection type, antiglare with hard coating
Number of Colors	512 colors (3 bits for each RGB subpixel)
Contrast Setting	Maximum setting
Viewing Direction	6:00 o' clock (Maximum contrast direction)
Interface	CMOS logic
Backlight	CCFL edgelight system

1-3 Block Diagram

1-3-1 Display

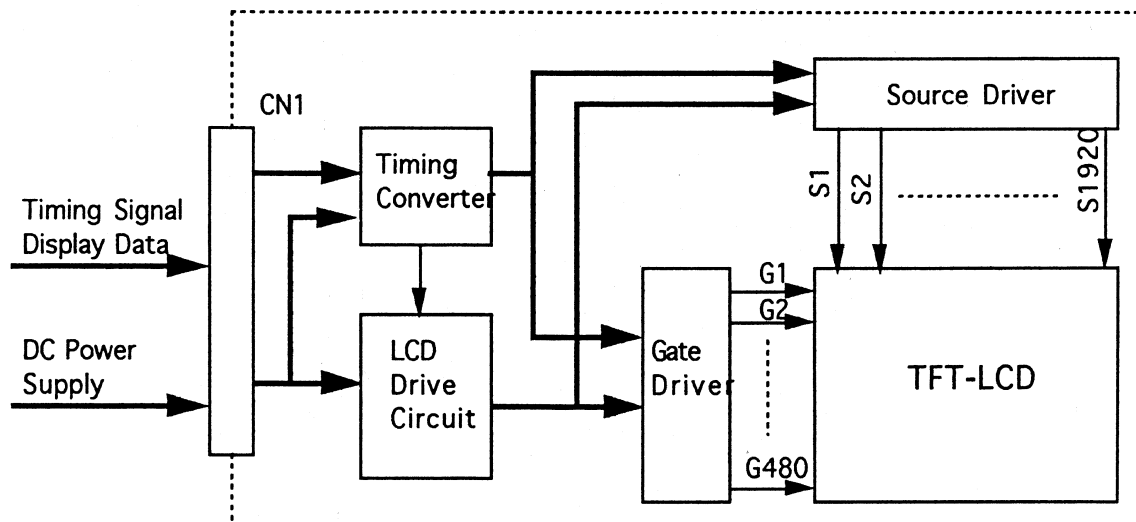



SPECIFICATIONS

1-3-2 Backlight Unit

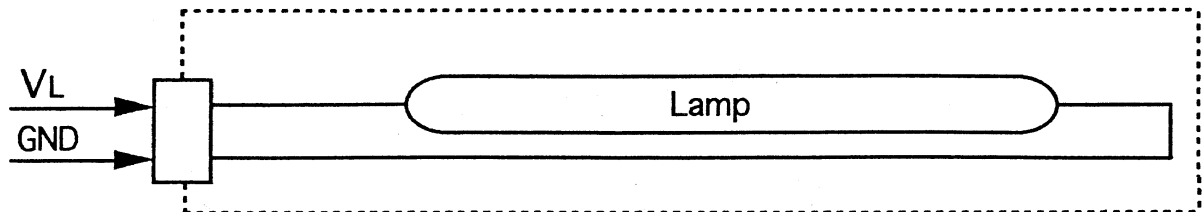

2. ABSOLUTE MAXIMUM RATINGS

Item	Symbol	Specification	Unit	Remark
Storage Temperature	T _{st}	-20 ... 60	°C	
Humidity *	RH	95 max	%	≤ 40°C
Operating Temperature	T _{op}	0 ... 50	°C	I _F =6mA
Humidity *	RH	95 max	%	≤ 40°C
5V Supply Voltage (logic)	V _{DD}	5 ± 0,25	V	
	V _{SS}	0 (GND)	V	
Input Voltage	V _{in}	V _{SS} <V _{IN} <V _{DD}	V	

* Note :

40°C , 95% RH , 120 h : Module will keep specified contrast ratio

40°C , 95% RH , 200 h : No damage to the module for practical use

See section "5 Reliability" for other conditions

3. DISPLAY CHARACTERISTICS

3-1 Physical Dimensions

Item	Standard Value	Unit
Display Pixels	640 (x3RGB) x 480	dots
Pixel Pitch	0,30 (0,10x3) x 0,30	mm
Screen Area	197,0 x 149,0	mm
Active Area	192,0 x 144,0 (9,5" diagonal)	mm
Display Outline	243,5 x 180,0 x 10,5	mm
Weight	580	grams

See display drawing HLD 0912-023020 DE for display as to overall dimensions



SPECIFICATIONS

TITLE : 9.5" TFT COLOR MODULE

NUMBER : HLD 0912-013020 REV.4 PAGE 5

3-2 Electro-Optical Characteristics

Item	Condition	Symbol	Min	Typ	Max	Unit
Contrast Ratio	$\theta=0^\circ, \phi=0^\circ$	CR	100	150	-	-
Viewing Angle	$\theta=0^\circ, \phi=-45^\circ$		5	-	-	-
	$\theta=0^\circ, \phi=45^\circ$		5	-	-	-
	$\theta=30^\circ, \phi=0^\circ$		10	-	-	-
	$\theta=-30^\circ, \phi=0^\circ$		2	-	-	-
Response Time	25°C ± 2.5°C	Rise	5	28	50	ms
		Fall				
Frame Frequency			50	60	70	Hz
Crosstalk (at RT)	$\theta=0^\circ, \phi=0^\circ$				5.5	%
Front Surface Hardness (Pencil)	JIS K5400		3			H
Front Antiglare Coating (Haze)	JIS K6714		4	-	13	%
Brightness (5 point average)	I _f = 6 mA		60	80		cd/m ²
Brightness Uniformity	I _f = 6 mA		-15		+15	%
Viewing Direction				6:00		o'clock
Dot Color			Neutral Grey to Dark Blue			
Color Coordinate (CIE 1931)	$\theta=0^\circ, \phi=0^\circ$ White	x	0.284	0.314	0.344	
		y	0.294	0.324	0.354	
	$\theta=0^\circ, \phi=0^\circ$ Red	x	0.539	0.559	0.579	
		y	0.321	0.341	0.361	
	$\theta=0^\circ, \phi=0^\circ$ Green	x	0.282	0.302	0.322	
		y	0.492	0.512	0.532	
	$\theta=0^\circ, \phi=0^\circ$ Blue	x	0.127	0.147	0.167	
		y	0.098	0.118	0.138	
Linearity & Viewing Lobe	RT $\theta=0^\circ, \phi=0^\circ$ Exhibit Normalized brightness Value	Black		0.8	1	%
		Gray1		2		%
		Gray2		5		%
		Gray3		11		%
		Gray4		27		%
		Gray5		48		%
		Gray6		82		%
		White		100	100	%
Residual Image (after 2h)	40°C				5	sec

Note :

RT means Room Temperature (25°C ± 5°C)

a) If not specially mentioned, CCFL supply current (I_f) shall be referred to section 3-3-2

b) Refer to section 4 for definitions and other information



SPECIFICATIONS

3-3 Electrical Characteristics

3-3-1 Display

Item	Symbol	Min	Typ	Max	Unit	Remark
Supply Voltage	V _{DD}	4,75	5	5,25	V	V _{DD} ± 5%
"High" Input Voltage	V _{ih}	0,7V _{DD}	-	V _{DD}	V	INPUT SIGNALS : DE,VS,HS,DCLK R0...R2 / G0...G2 B0...B2
"Low" Input Voltage	V _{il}	0	-	0,3V _{DD}	V	
Input Leakage Current	I _{CL} ,I _{CH}	-20	-	20	µA	
Input Capacitance	C _i	-	-	120	pF	
Supply Current	I _{DD}	-	260	300	mA	V _{DD} =5V @ 60H
Power Consumption	P _c	-	1,3	1,5	W	V _{DD} =5V @ 60H

3-3-2 CCFL Backlight

Item	Symbol	Min	Typ	Max	Unit	Remark
Lamp Current	I _f		6		mA	
Lamp Voltage	V _L	477	530	583	V _{rms}	
Power Consumption			3,1		W _{rms}	
Starting Voltage	V _{rms}	1160			V _{rms}	0°C ± 2°C
		750			V _{rms}	25°C ± 2°C
Driving Frequency			30		kHz	*1
Life (half brightness time)		10000			h	*2
On / Off cycles		100000			times	30 sec. On - Off

Note :

*1 : Operating without of range of specified frequency as above can affect brightness and uniformity of the product.

*2 : Typical lifetime is 20.000 h



SPECIFICATIONS

3-3-3 Interface Description Display

Connector (CN1) for display

Manufacturer : HIROSE ELECTRIC CO., LTD

Part Number : DF9B-31P-1V

Pin No.	Signal Name	Function
1	NC	No Connection
2	GND	Ground
3	R0 (LSB)	Red Data 0
4	VS	Vertical Sync
5	R1	Red Data 1
6	HS	Horizontal Sync
7	R2 (MSB)	Red Data 2
8	GND	Ground
9	GND	Ground
10	CLK	Data Clock
11	NC	No Connection
12	GND	Ground
13	G0 (LSB)	Green Data 0
14	NC	No Connection
15	GND	Ground
16	NC	No Connection
17	G1	Green Data 1
18	NC	No Connection
19	G2 (MSB)	Green Data 2
20	GND	Ground
21	GND	Ground
22	V _{DD}	Power Supply +5V
23	NC	No Connection
24	V _{DD}	Power Supply +5V
25	B0 (LSB)	Blue Data 0
26	NC	No Connection
27	GND	Ground
28	DE	Display Data Enable
29	B1	Blue Data 1
30	GND	Ground
31	B2 (MSB)	Blue Data 2

POLARITY OF SYNC SIGNAL

MODE	480 lines	400 lines	350 lines
HSYNC	Negative	Negative	Positive
VSYNC	Negative	Positive	Negative

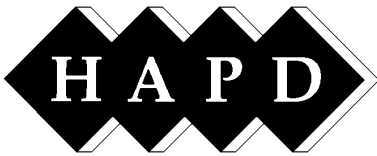

SPECIFICATIONS

3-3-4 Interface Description Backlight

Connector (CN2) for backlight

Manufacturer : JAPAN SOLDERLESS TERMINAL MFG. CO. LTD (JST)

Part Number : BHR-03VS-1

Pin No.	Signal Name	Function
1	VL	Power Supply
2	NC	No Connection
3	GND	Ground (0V)

3-3-5 Data Input Format

Display Position of Input Data (W-H)

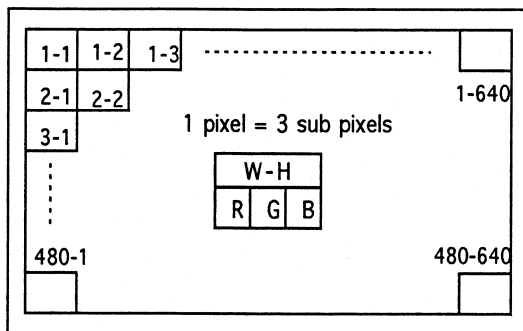

3-3-6 Power ON/OFF Sequential Timing

In order to prevent a latch-up or DC operation of the LCD module, this power ON / OFF sequence should be used.

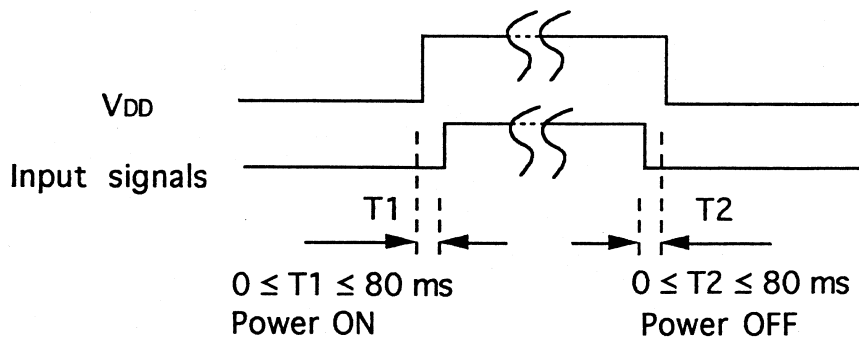

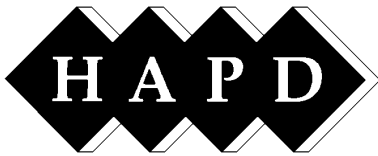

SPECIFICATIONS

3-3-7 Data Signal, Basic Color and Gray Scale of Each Color

Basic Color	Data Signal								
	R2	R1	R0	G2	G1	G0	B2	B1	B0
Black	0	0	0	0	0	0	0	0	0
Blue	0	0	0	0	0	0	1	1	1
Green	0	0	0	1	1	1	0	0	0
Cyan	0	0	0	1	1	1	1	1	1
Red	1	1	1	0	0	0	0	0	0
Magenta	1	1	1	0	0	0	1	1	1
Yellow	1	1	1	1	1	1	0	0	0
White	1	1	1	1	1	1	1	1	1

Gray Scale of	Data Signal			Gray Level (decimal)
	RGB	RGB	RGB	
Red / Green / Blue	2	1	0	
Black	0	0	0	= 0
1st Gray	0	0	0	= 1
2nd Gray	0	0	0	= 2
3rd Gray	0	0	0	= 3
4th Gray	0	0	0	= 4
5th Gray	0	0	0	= 5
6th Gray	0	0	0	= 6
Red / Green / Blue	1	1	1	= 7

0 = Low Level Voltage
 1 = High Level Voltage

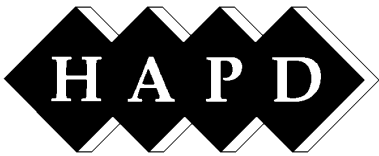

SPECIFICATIONS

3-3-8 Interface Timing Diagram

Interface Timing (350 lines mode)

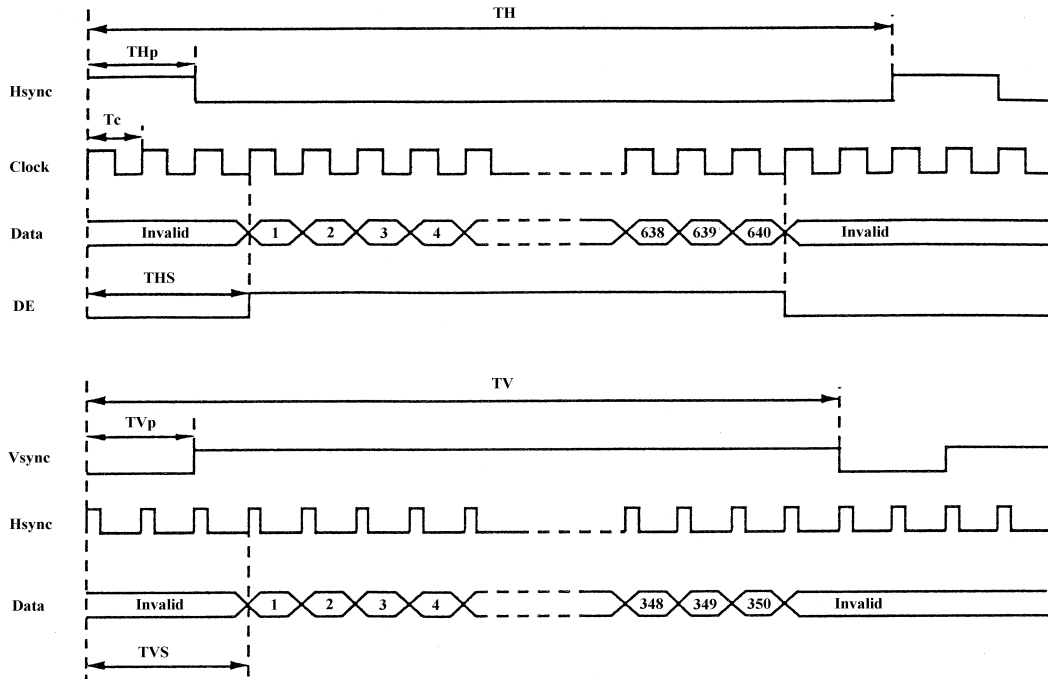

Interface Timing (400 lines mode)

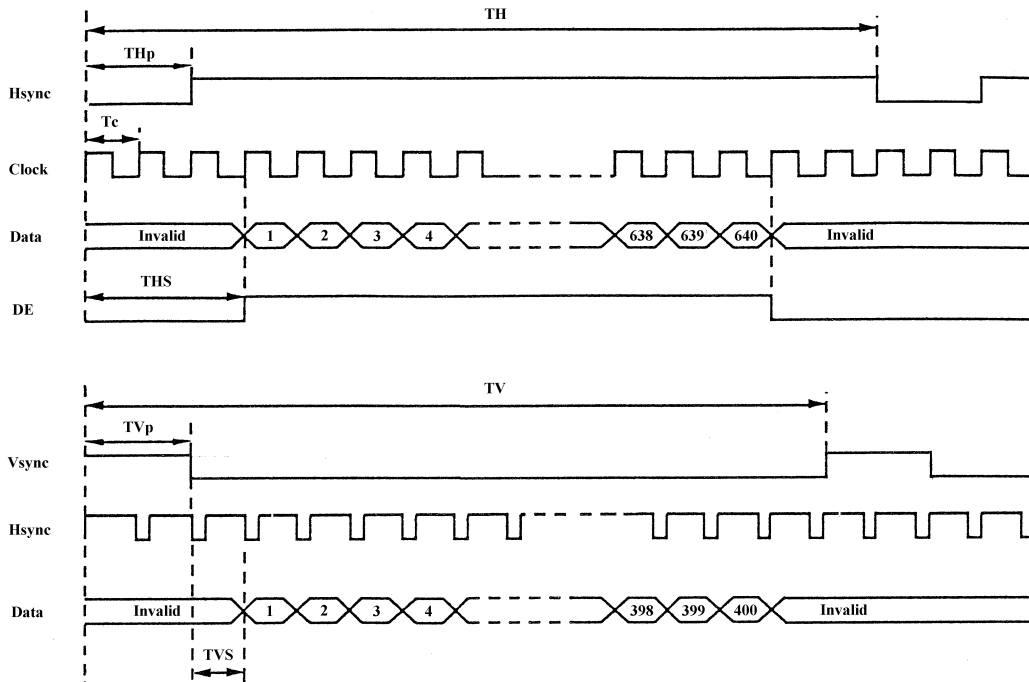

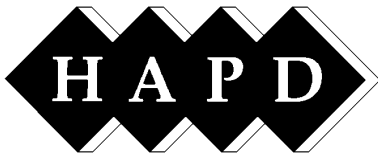

SPECIFICATIONS

3-3-8 Interface Timing Diagram

Interface Timing (480 lines mode)

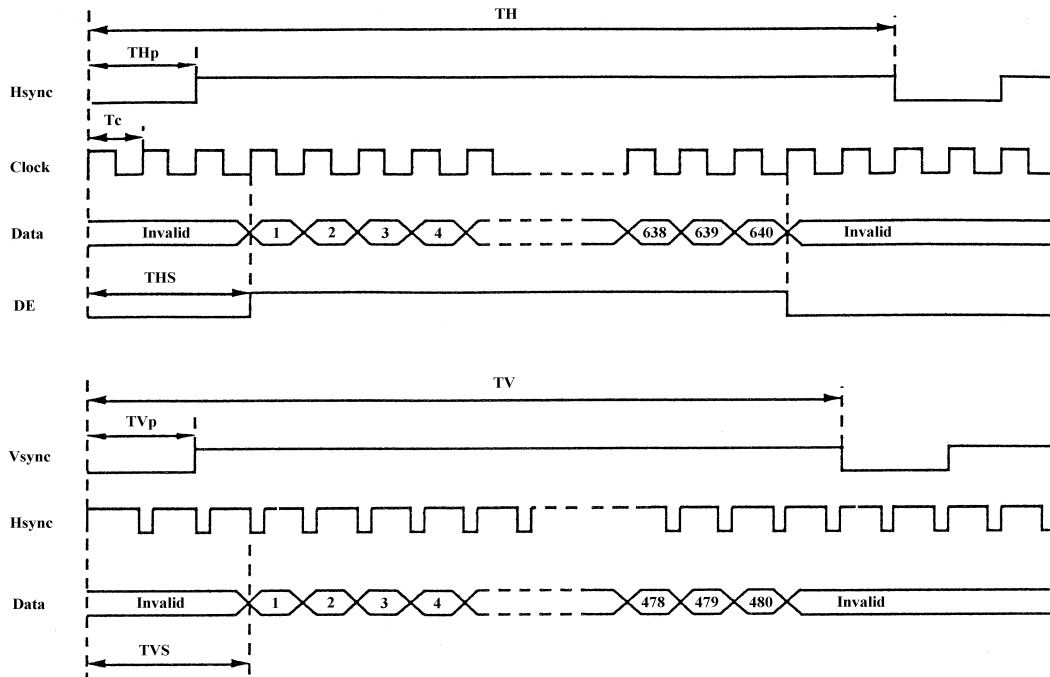

	Parameter	Symbol	Min	Typ	Max	Unit	Mode	
DCLK	Frequency	1/T _c	-	25.175	28.322	MHz	all	
	Pulse Width	TH _p	63	96	96	clock	all	
HS	Display Start	TH _s	107	-	-	clock	all	
	Cycle	TH	770	800	900	clock	all	
VS	Pulse Width	TV _p	1	2	9	line	all	
	Display Start	TV _s	34	34	34	line	480	
			-	34	-	line	400	
			-	61	-	line	350	
	Cycle	TV			16,7 / 525		ms / line	480
					14,3 / 449		ms	400
				14,3 / 449		line	350	



SPECIFICATIONS

3-3-9 Detailed Horizontal Timing Diagram

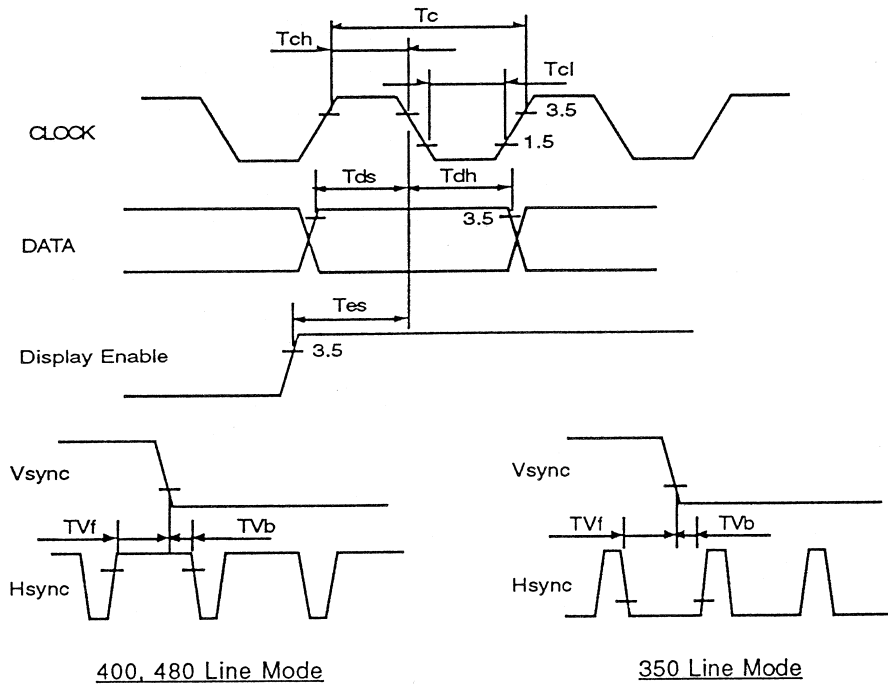

Parameter	Symbol	Min	Max	Unit	Mode
CLOCK	High Time	5		ns	all
	Low Time	10		ns	all
DATA	Set up Time	5		ns	all
	Hold Time	10		ns	all
DISPLAY ENABLE	Setup Time	5		ns	all
HSYNC - VSYNC PHASE DIFFERENCE	Front	0		ns	all
	Back	0		ns	all

4. DEFINITION AND MEASURING METHOD

- Note 1) Viewing Angle, Contrast Ratio, Response Time, Reflectance and Chromaticity are measured in a dark room at panel center.
- 2) Brightness and Brightness Uniformity are measured at 5 points as described in Fig. 4
- 3) Backlight is warmed up for more than 15 minutes to make its condition stable.

4-1 Viewing Angle

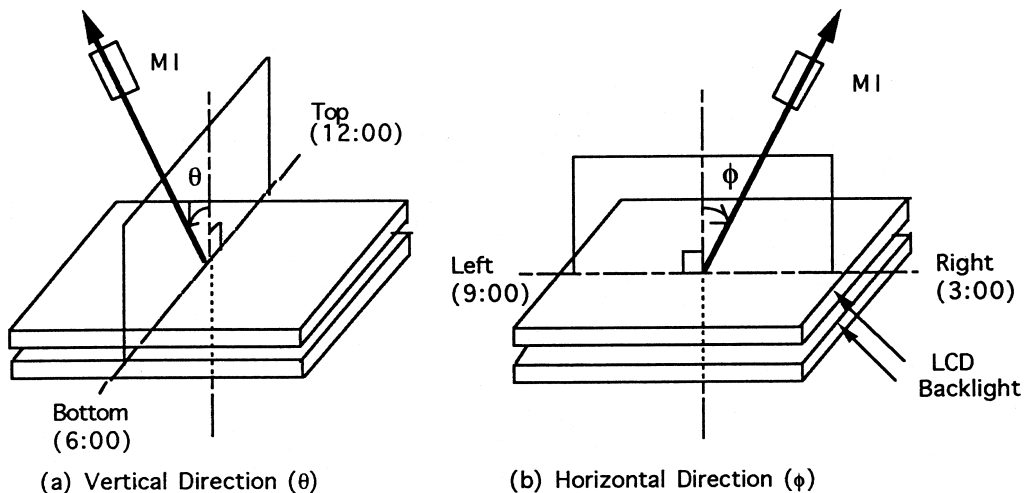

Figure 1

4-2 Optical Measurement

4-2-1 Measurement Instrument (MI)

Luminance & Chromaticity	:	PHOTORESEARCH / PRITCHARD 1980B/SS or TOPCON / Color Luminance Meter BM5(A)
Response Time	:	PRITCHARD 1980/SS or photomultiplier
Measurement Condition	:	Dark Room / Room Temperature
Measurement Diameter	:	5 ... 10 mm

4-2-2 Module Driving Conditions

Frame Frequency	:	60 Hz
Supply Voltage	:	Refer to Section 3-3-1
Backlight Supply Current	:	Refer to Section 3-3-2

4-3 Contrast Ratio (CR)

Definition Contrast Ratio = $\frac{\text{Luminance in White Level (Gray Level 63)}}{\text{Luminance in Black Level (Gray Level 0)}}$

4-4 Definition of Response Time (T_r , T_f)

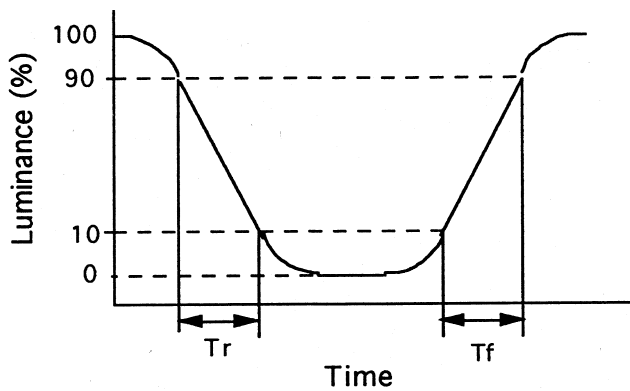

Figure 2

4-5 Definition of Reflectance

Reflectance : $R = R_s / R_{ref} \times 100\%$
 R_s : Brightness of LCD reflectance
 R_{ref} : Brightness of calibrated front surface mirror reflectance

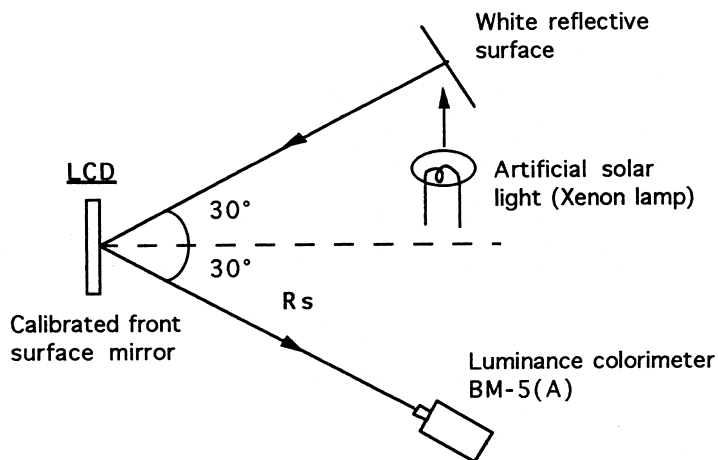

Figure 3



SPECIFICATIONS

4-6 Definition of Brightness and Brightness Uniformity

Brightness : Average value of 5 points shown in Figure 4

$$\text{Brightness Uniformity} : \frac{\text{Max (Min) - Average}}{\text{Average}} \times 100 \%$$

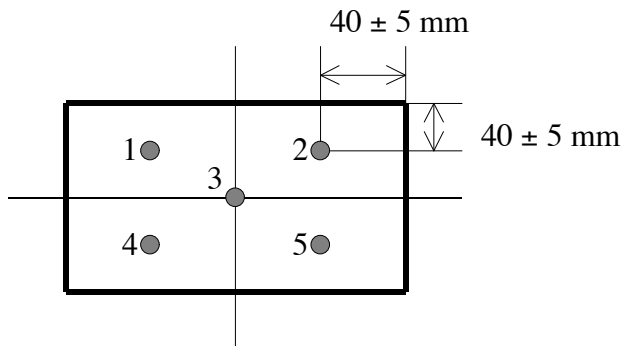

Figure 4

Condition : Display Pattern : Gray Level 7 (white)

4-7 Supply Current (Display without Backlight)

Maximum Current Display Pattern : Line by line vertical stripes with Gray level 0 and 7

Typical Current Display Pattern : 8 vertical gray shades

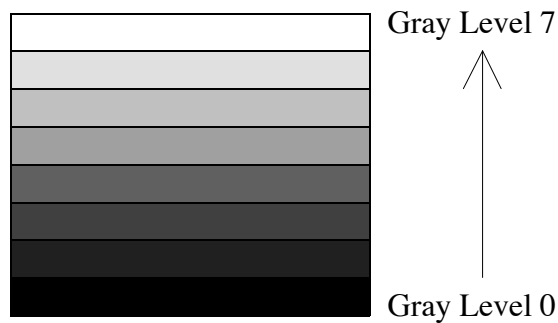

Figure 5



SPECIFICATIONS

5. RELIABILITY

5-1 Test Item and Condition

Test Item		Condition	
1	Low Temperature Storage	- 20°C x 120 h	Non-operating
2	High Temperature Storage	+ 60°C x 120 h	Non-operating
3	High Temp. / Humidity Soak	40°C , 90% RH (72h) no condensation	Operating
4	Solar Radiation	Sunshine Carbon arc / 10 days	Non-operating
5	Thermal Shock	-25°C (2h) <-> 60°C (2h) x 5 cycles	Non-operating
6	Vibration	10...55 Hz, Full amplitude 1.5 mm p-p (X,Y,Z, 3 axis, 2h each)	Non-operating
7	Shock	3 axis (± X,Y,Z) 80G, 6ms	Non-operating
8	MTBF (Display)	30.000 h at 25°C	Operating
9	Backlight Life	25°C , I _f = 6 mA	Operating
10	ESD	250Ω, 200pF, 8kV, LCD surface	Non-operating

5-2 Check Item and Failure Criteria

Test Item		Condition					
		Contrast Ratio ^{*1}	Viewing Angle ^{*2}	Supply Current	Chromaticity	Defects, Voids ^{*3}	Cosmetic
1	Low Temp. Storage	A	D	A	B	A	C
2	High Temp. Storage	A	D	A	B	A	C
3	High Temp. / Hum. Soak	A	D	A	B	A	C
4	Solar Radiation	A	D	A	B	A	C
5	Thermal Shock	A	D	A	B	A	C
6	Vibration	-	-	-	-	A	C
7	Shock	-	-	-	-	A	C
8	MTBF (Display)	B	-	A	B	A	C
9	Backlight Life ^{*4}	10.000 hours min.					
10	ESD	Shall be functional					

Notes

*1 : Contrast Ratio Measuring Point ($\theta=0^\circ$, $\phi=0^\circ$)

*2 : Viewing Angle Measuring Point ($\theta= \pm 30^\circ$, $\phi=0^\circ$, $\theta=0^\circ$, $\phi= \pm 45^\circ$)

*3 : Defects, Voids, Inverted Pixels

*4 : Backlight life is defined, that the brightness is decreased to 50% of the initial brightness

- : No check

A : To meet specification

C : To meet visual inspection specification

B : No remarkable change

D : $CR \geq 2$



SPECIFICATIONS

5-3 Functional defects of dots

5-3-1 Bright subpixels, Dark subpixels

	Count	Reject
Bright subpixel / High Level	$N \leq 15$	$N > 15$
Bright subpixel / High Level and Low Level	$N \leq 25$	$N > 25$
Dark subpixel	$N \leq 15$	$N > 15$

5-3-2 Adjacent defective dots

	Count	Reject
Adjacent 2 or 3 subpixels	$N \leq 5$	$N > 5$
Adjacent 4 subpixels		$N > 0$

5-3-3 Block Defects within 15 mm circle

Count	Reject
$N \leq 4$	$N > 4$

Note : One block of adjacent defective subpixels shall be counted as a block of defects

5-3-4 Definitions

Defective subpixel ; Bigger than 1/2 subpixel

Bright subpixel / High Level :	Always 6th gray ... white brightness at black pattern
Bright subpixel / Low Level :	Always 4th gray ... 5th gray brightness at black pattern
Dark subpixel :	Always black at each red / green or blue pattern
Definition of gray level :	Black / 1st gray / 2nd gray 5th gray / 6th gray / white

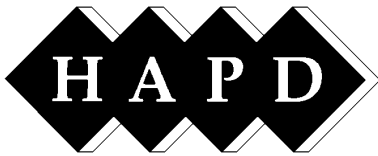

SPECIFICATIONS

TITLE : 9.5" TFT COLOR MODULE

NUMBER : HLD 0912-013020 REV.4 PAGE 18

6. APPLICABLE OTHER DOCUMENTS

Outline Drawing : HLD 0912-023020 DE
Packaging Style : HLD 0912-013010 HE
Shipping Container : HLD 0912-000010 HE

7. CAUTION AND HANDLING PRECAUTION

7-1 Handling

1. Do not disassemble the module
2. Since the LCD cell is made of glass, do not apply strong mechanical impact or static load onto it. Handle with care, and do not twist or bend the LCD module.
3. In case the LCD cell is broken, do not sip or drink leaked liquid crystal material. If the liquid crystal material touched your skin, wash it out with soap immediately.
4. Do not drop water or any chemicals onto the display surface.
5. Handle the polarizers with care as it may be easily scratched. Do not press or rub them with any hard object.
6. Do not apply high electrostatic voltage to the LCD module. It may damage CMOS / LSI circuit in the LCD module. Ground yourself when you touch the LCD module directly.
7. When you handle the LCD module for incoming inspection or assembly, use soft fingerstalls or gloves in order to keep the display quality.
8. Do not pull or fold the CCFL cable

7-2 Storage

1. Store the LCD module within the ratings in order to keep the performance and prevent from any damages. Never store the LCD module under abnormal conditions of high temperature and high humidity. It is recommended that the LCD module shall be stored under the condition of temperature between 0°C and 35°C and humidity less than 60%.
2. Never store LCD module with exposure to direct sunlight

7-3 Operation

1. Do not connect or disconnect the LCD module to or from the system when power is on.
2. Use the LCD module within the ratings in order to keep the performance and prevent from any damages. Never use the LCD module under abnormal conditions of high temperature and high humidity.

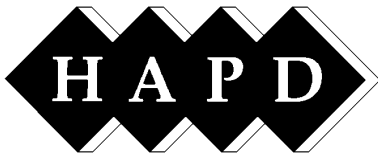

SPECIFICATIONS

TITLE : 9.5" TFT COLOR MODULE

NUMBER : HLD 0912-013020 REV.4 PAGE 19

7-4 Others

Avoid any condensation of water during storage or operation as it may cause misoperation or disconnection of electrodes.

8. WARRANTY

8-1 Incoming Inspection

Incoming inspection by the customer shall be performed within thirty (30) days from the shipping date.

8-2 Warranty Period

HOSIDEN and PHILIPS warrants the LCD modules for a period of 6 months from the shipping date when stored or used under normal conditions.

9. OTHERS

Any and all questions or disputes arising out of or related to this specification shall be settled by a consultation between the customer and HOSIDEN and PHILIPS or its representatives.

10. DRAWING

See following page.

If a more detailed drawing is necessary please contact HOSIDEN and PHILIPS or its representatives.

The information given in this document is carefully checked and believed to be reliable.

HOSIDEN AND PHILIPS DISPLAY CORPORATION reserves the right to make changes in product or specification at any time and without further notice.
HOSIDEN AND PHILIPS DISPLAY CORPORATION products are not intended for use in systems in which failures of product could result in personal injury.
All mentioned trademarks are registered trademarks of their owner.



SPECIFICATIONS

TITLE : 9.5" TFT COLOR MODULE

NUMBER : HLD 0912-013020 REV.4 PAGE 20

