

LQ084S3LG01 TFT-LCD Module

Product Specification

August 2007

Strong 2 SVGA LCD Module featuring
400 nits brightness with 600:1 contrast.

Full Specifications Listing

PREPARED BY:	SHARP	SPEC No. LCY-W07802
APPROVED BY:		FILE No.
		ISSUED: Aug.14.2007
		PAGE : 24pages
	MOBILE LIQUID CRYSTAL DISPLAY GROUP SHARP CORPORATION SPECIFICATION	APPLICABLE GROUP MOBILE LIQUID CRYSTAL DISPLAY GROUP

DEVICE SPECIFICATION FOR
TFT-LCD module
 MODEL No. LQ084S3LG01

These parts have corresponded with the RoHS directive.

CUSTOMER'S APPROVAL

DATE _____

BY _____

PRESENTED

BY *K. Yamamoto*
 K. YAMAMOTO
 General Manager
 Mobile LCD Merchandise Design Center
 WUXI SHARP ELECTRONIC COMPONENTS CO., LTD.

- ◎These specification sheets are the proprietary product of SHARP CORPORATION(“SHARP”) and include materials protected under copyright of SHARP. Do not reproduce or cause any third party to reproduce them in any form or by any means, electronic or mechanical, for any purpose, in whole or in part, without the express written permission of SHARP.

- ◎The device listed in this technical literature was designed and manufactured for use in OA equipment.

- ◎In case of using the device for applications such as control and safety equipment for transportation(aircraft, trains, automobiles, etc.), rescue and security equipment and various safety related equipment which require higher reliability and safety, take into consideration that appropriate measures such as fail-safe functions and redundant system design should be taken.

- ◎Do not use the device for equipment that requires an extreme level of reliability, such as aerospace applications, telecommunication equipment(trunk lines), nuclear power control equipment and medical or other equipment for life support.

- ◎SHARP assumes no responsibility for any damage resulting from the use of the device which does not comply with the instructions and the precautions specified in these specification sheets.

- ◎Contact and consult with a SHARP sales representative for any questions about this device.

1. Application

This specification applies to the color TFT-LCD module, LQ084S3LG01.

2. Overview

This module is a color active matrix LCD module incorporating amorphous silicon TFT (Thin Film Transistor). It is composed of a color TFT-LCD panel, driver ICs, control circuit, power supply circuit and a back light unit. Graphics and texts can be displayed on a 800×RGB×600 dots panel with about 16 million colors by using LVDS (Low Voltage Differential Signaling) and supplying +3.3V DC supply voltages for TFT-LCD panel driving and supply voltage for backlight.

(Note: Backlight-driving DC/AC inverter is not built in this module.)

- a) Fine images with stripe aligned 480,000 pixels on 8.4 inch diagonal screen
- b) Adapting a wide viewing angle technology [best viewing angle: 6 o'clock direction]
(12 o'clock direction is also available by the function to flip the screen horizontally or vertically)
- c) High contrast, thanks to active matrix drive system
- d) AG(Anti Glare) polarizing filter
- e) Light and slim compact module
- f) Natural coloring reproducibility by employing normally-white-mode, which has good nature in coloring
- g) Image inversion both horizontally and vertically
- h) This module is adapted to RoHS compliance.

3. Mechanical Specifications

Parameter	Specifications	Unit
Display size	21.3 (Diagonal)	cm
	8.4 (Diagonal)	Inch
Active area	170.4 (H)×127.8 (V)	mm
Pixel format	800 (H)×600 (V)	Pixel
	(1 pixel=R+G+B dots)	
Pixel pitch	0.213 (H)×0.213 (V)	mm
Pixel configuration	R, G, B vertical stripe	
Display mode	Normally white	
Unit outline dimensions *1	199.5(W)×149.5(H)×11.6(D)	mm
Mass	405(MAX)	g
Surface treatment	Anti-glare and hard-coating	

*1.Note: excluding back light cables.

The thickness of module (D) doesn't contain the projection.

Outline dimensions are shown in Fig.1.

4. Input Terminals

4-1. TFT-LCD panel driving

CN1 (Interface signals and +3.3V DC power supply)

Using connectors : 20186-020E-11 (I-PEX)

Corresponding connectors : FI-SE20ME(Japan Aviation Electronics Industry, Ltd.)
 FI-SE20S (Japan Aviation Electronics Industry, Ltd.)

Using LVDS Receiver : Contained in a control IC. [THC63LVDF84A(Thine) compatible]

Corresponding LVDS Transmitter : THC63LVDM83R(Thine) or compatible

Pin No.	Symbol	Function	Remark
1	Vcc	+3.3V Power supply	
2	Vcc	+3.3V Power supply	
3	GND	Ground	
4	GND	Ground	
5	RxIN0-	LVDS CH0 data signal (-)	LVDS
6	RxIN0+	LVDS CH0 data signal (+)	LVDS
7	GND	Ground	
8	RxIN1-	LVDS CH1 data signal (-)	LVDS
9	RxIN1+	LVDS CH1 data signal (+)	LVDS
10	GND	Ground	
11	RxIN2-	LVDS CH2 data signal (-)	LVDS
12	RxIN2+	LVDS CH2 data signal (+)	LVDS
13	GND	Ground	
14	RxCLKIN-	LVDS CK- data signal (-)	LVDS
15	RxCLKIN+	LVDS CK+ data signal (+)	LVDS
16	GND	Ground	
17	RxIN3-	LVDS CH3 data signal (-)	LVDS
18	RxIN3+	LVDS CH3 data signal (+)	LVDS
19	REV	Reversing terminal	
20	LVDS_SET	SELLVDS	【Note1】

※ As for the pin No.1 of this connector, please refer to the figure on page 20.

【Note1】

REV : High

REV:Low



4-2 Data Mapping

1) 8 bit input

【Note1】 pin assignment with SELLVDS pin (Thine:THC63LVDM83R)

Transmitter		20pin LVDS_SET	
Pin No	Data	=H (3.3V)	=L (GND) or Open
51	TA0	R0 (LSB)	R2
52	TA1	R1	R3
54	TA2	R2	R4
55	TA3	R3	R5
56	TA4	R4	R6
3	TA5	R5	R7 (MSB)
4	TA6	G0 (LSB)	G2
6	TB0	G1	G3
7	TB1	G2	G4
11	TB2	G3	G5
12	TB3	G4	G6
14	TB4	G5	G7 (MSB)
15	TB5	B0 (LSB)	B2
19	TB6	B1	B3
20	TC0	B2	B4
22	TC1	B3	B5
23	TC2	B4	B6
24	TC3	B5	B7 (MSB)
27	TC4	(NA)	(NA)
28	TC5	(NA)	(NA)
30	TC6	DE	DE
50	TD0	R6	R0 (LSB)
2	TD1	R7 (MSB)	R1
8	TD2	G6	G0 (LSB)
10	TD3	G7 (MSB)	G1
16	TD4	B6	B0 (LSB)
18	TD5	B7 (MSB)	B1
25	TD6	(NA)	(NA)

< SELLVDS = H >

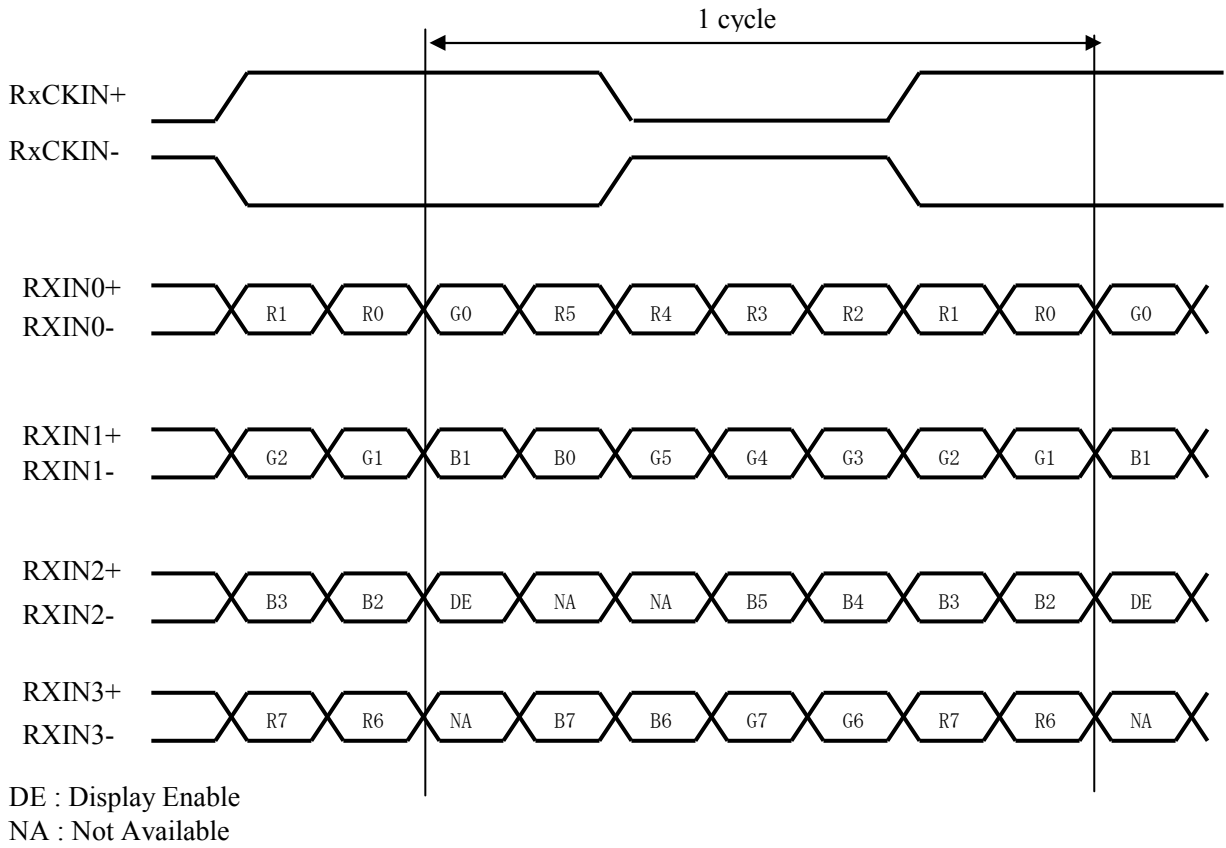

< SELLVDS = L or Open >

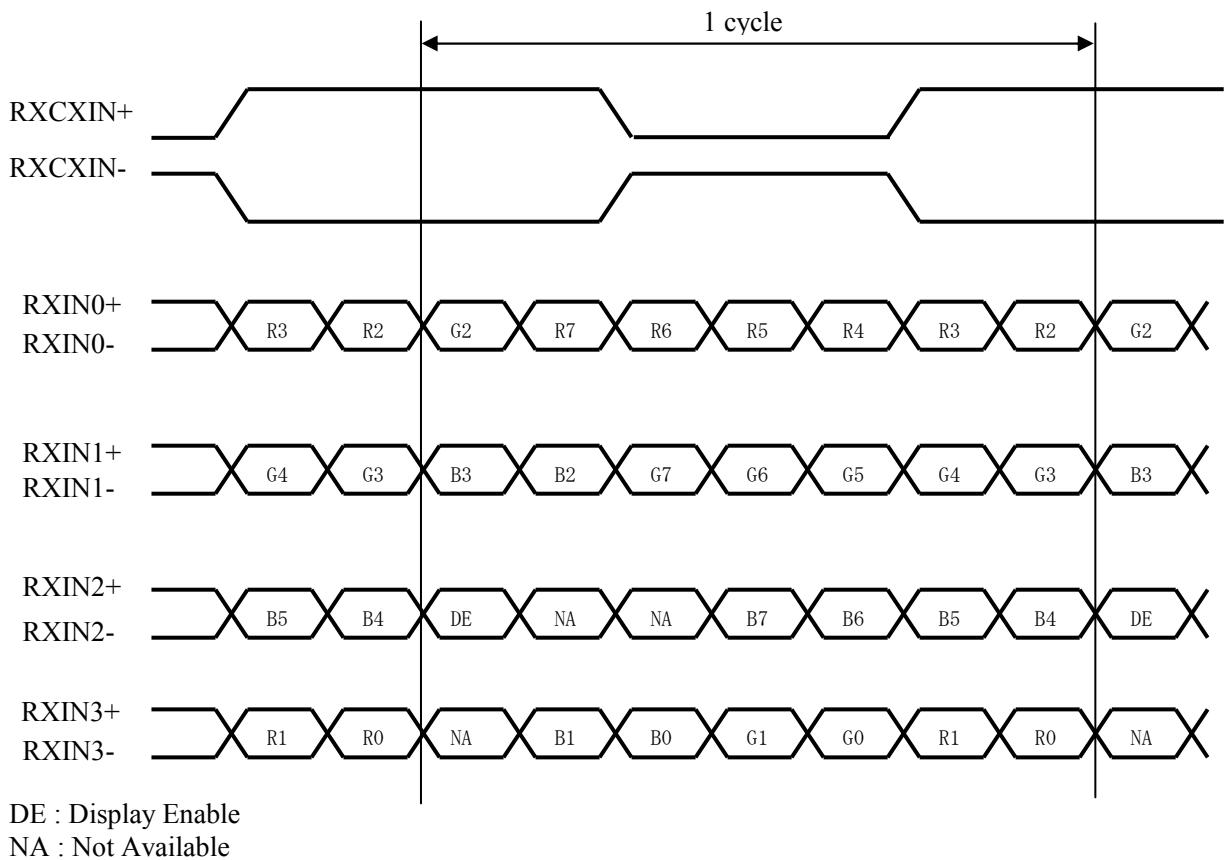

2) 6 bit input

【Note1】 pin assignment with SELLVDS pin (Thine:THC63LVDM83R)

Transmitter		20pin SELLVDS	
Pin No	Data	=H (3.3V)	=L (GND) or Open
51	TA0	—	R0 (LSB)
52	TA1	—	R1
54	TA2	—	R2
55	TA3	—	R3
56	TA4	—	R4
3	TA5	—	R5 (MSB)
4	TA6	—	G0 (LSB)
6	TB0	—	G1
7	TB1	—	G2
11	TB2	—	G3
12	TB3	—	G4
14	TB4	—	G5 (MSB)
15	TB5	—	B0 (LSB)
19	TB6	—	B1
20	TC0	—	B2
22	TC1	—	B3
23	TC2	—	B4
24	TC3	—	B5 (MSB)
27	TC4	—	(NA)
28	TC5	—	(NA)
30	TC6	—	DE
50	TD0	—	GND
2	TD1	—	GND
8	TD2	—	GND
10	TD3	—	GND
16	TD4	—	GND
18	TD5	—	GND
25	TD6	—	(NA)

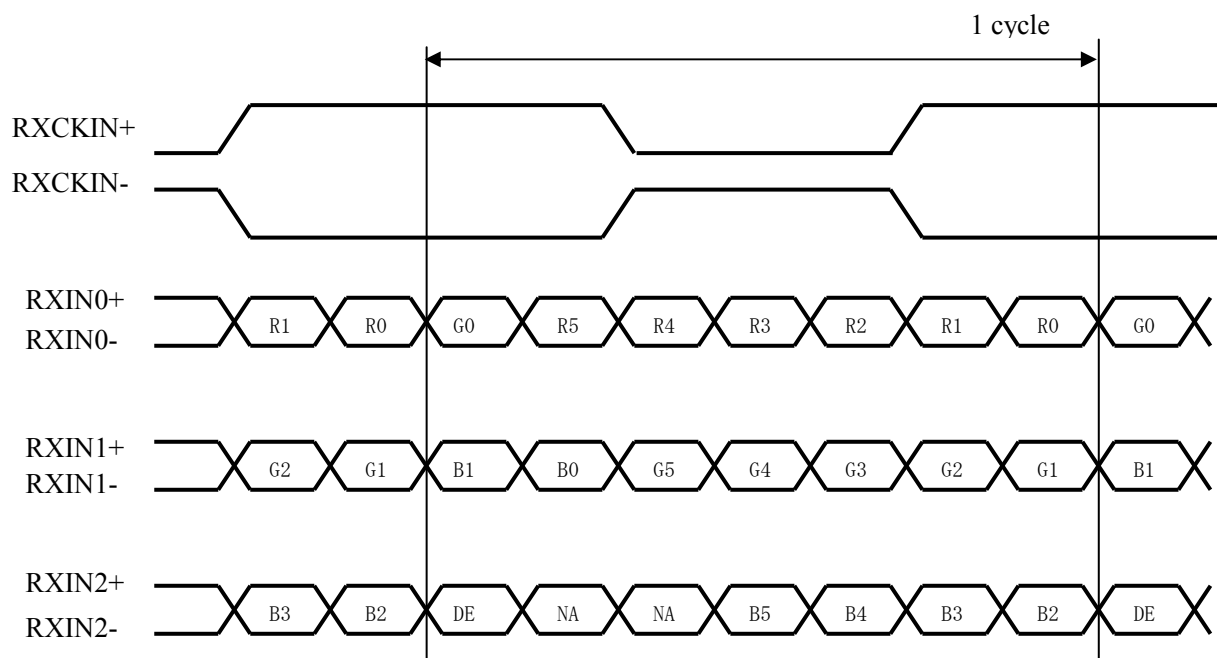

DE : Display Enable

NA : Not Available

« About the connection of RXIN3+ and RXIN3-, in case of supplying 6bit signals. »

- RXIN3- : Please keep the input voltage higher than 1.7V, but less than the power supply voltage (VLDS+0.3V) of the control IC.
- RXIN3+ : Please be connected to the GND.

(Terminal processing example)

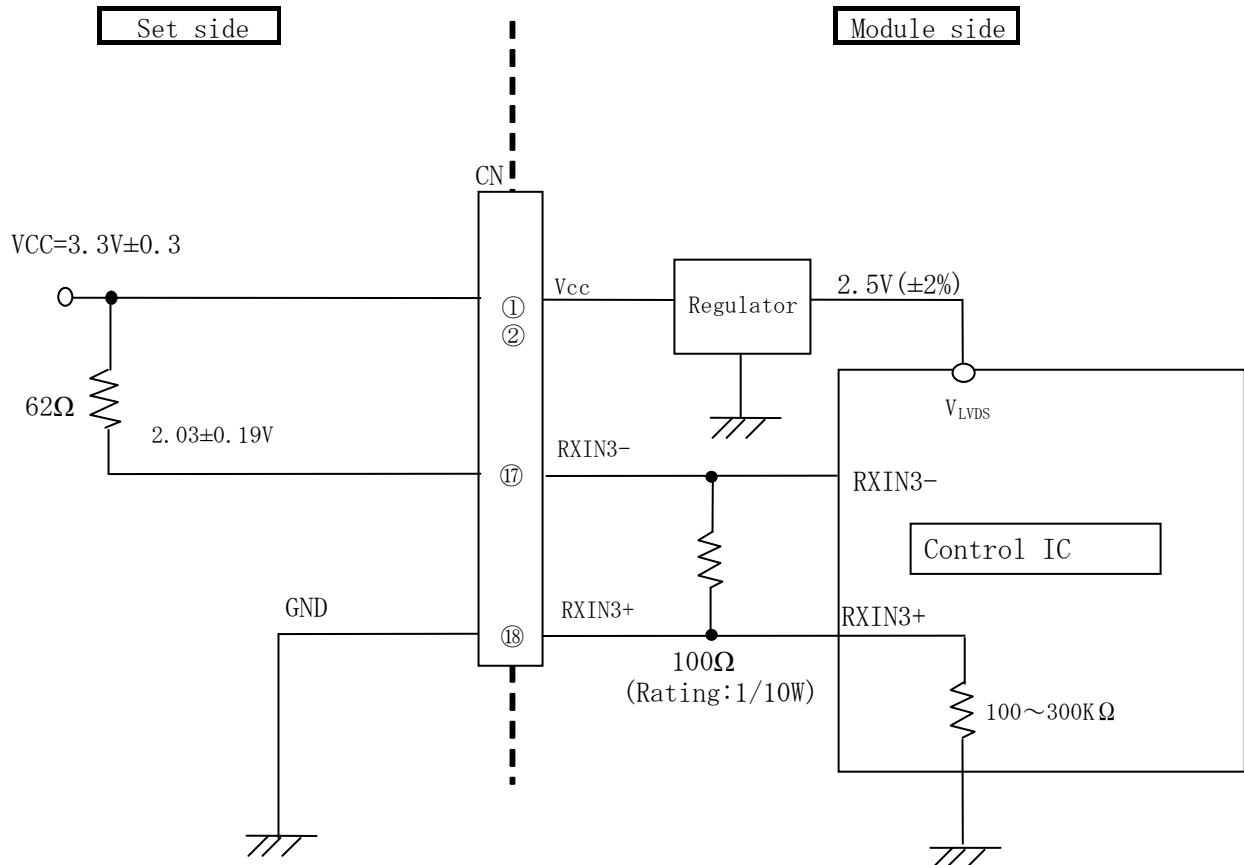

(Computer Side)

(TFT-LCD side)

①8Bit Mode

SELLVDS=H (20 pin=3.3V)

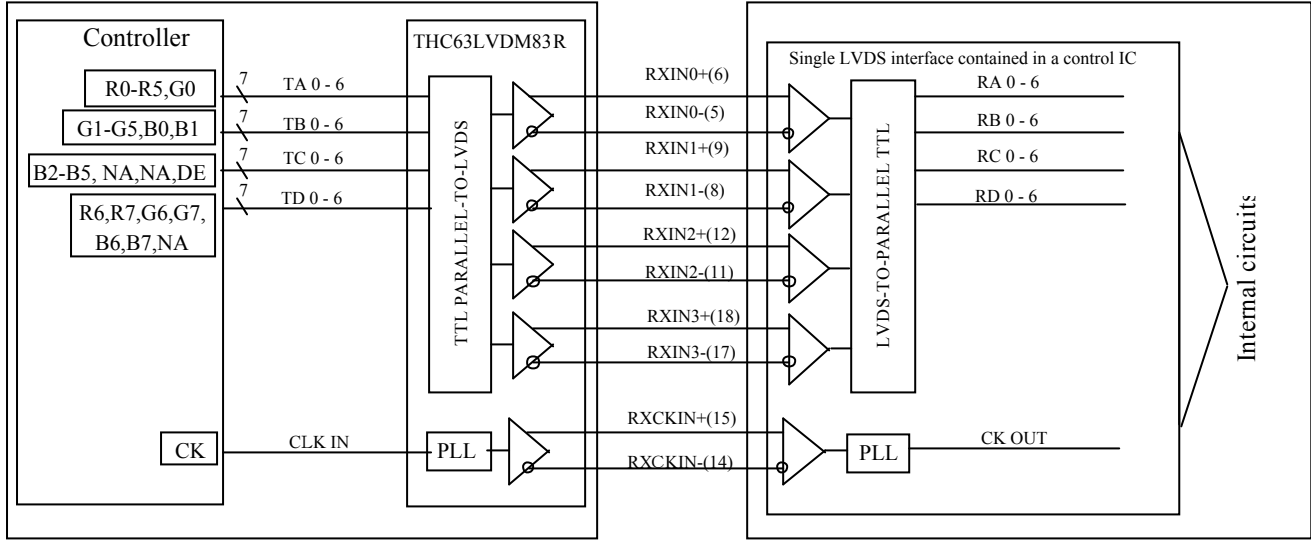

②8Bit Mode

SELLVDS=L(GND or OPEN)]

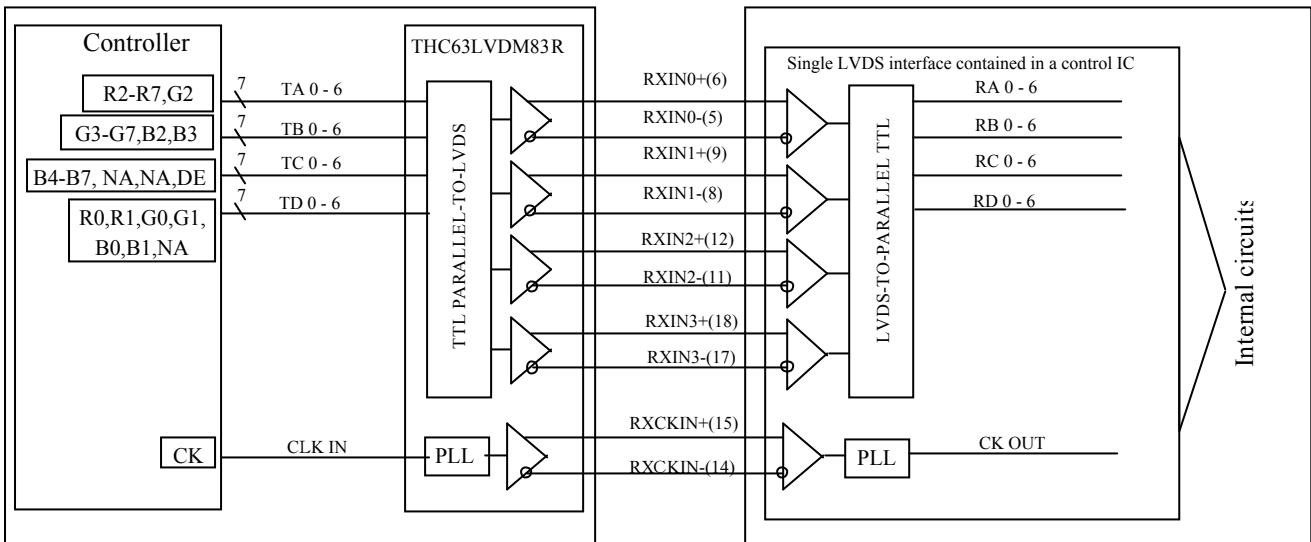

③6Bit Mode

SELLVDS=L (GND or OPEN)]

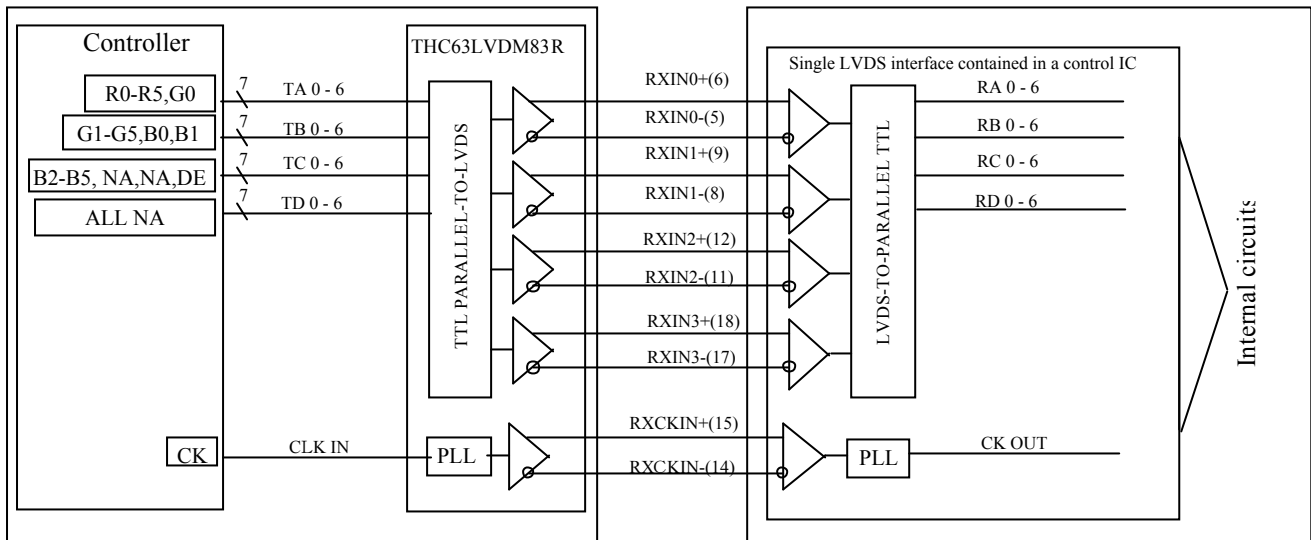

4-4. Backlight

The module-side connector : BHR-04VS-1 (JST)

The user-side connector : SM04(4.0)B-BHS (JST)

Pin no.	symbol	Function
1	V _{HIGH}	Power supply for lamp 1 (High voltage side)
2	V _{HIGH}	Power supply for lamp 2 (High voltage side)
3	NC	Open
4	V _{LOW}	Power supply for lamp 1,2 (Low voltage side)

【Note】

The input voltage wave forms to terminal (1) and terminal (2) should be in a same phase.

It has the possibility to discharge abnormally between the terminals in case of input in a reversed phase.

5 Absolute Maximum Ratings

Parameter	Symbol	Condition	Ratings	Unit	Remark
Input voltage	V _I	T _a =25°C	-0.3 ~ V _{CC} +0.3	V	[Note 1]
Supply voltage	V _{CC}	T _a =25°C	0 ~ +4.0	V	-
Storage temperature	T _{stg}	-	-30 ~ +80	°C	[Note 2,3,4,5]
Operating temperature (Panel surface)	T _{opp}	-	-30 ~ +80	°C	

[Note 1] CK, R0 ~ R5, G0 ~ G5, B0 ~ B5 and ENAB

[Note 2] Preserve it within this range.

[Note 3] Humidity: Less than 95%RH at T_a ≤ 40°C and

Maximum wet-bulb temperature must not exceed 39°C at T_a>40°C,
with no condensation.

[Note 4] The operating temperature only guarantees operation of the circuit. For contrast, speed response,
and other factors related to display quality, judgment is done using the ambient temperature T_a =+25°C.

[Note 5] This rating applies to all parts of the module and should not be exceed.

6. Electrical Characteristics

6-1. TFT-LCD panel driving

Ta=25°C

Parameter	Symbol	Min.	Typ.	Max.	Unit	Remark
Supply voltage	V _{CC}	+3.0	+3.3	+3.6	V	【Note1】
Current dissipation	I _{CC}	—	250	380	mA	【Note2】
Input voltage (“High” state)	V _{RIH}	V _{CC} ×0.7			V	【Note3】
Input voltage (“Low” state)	V _{RIL}			V _{CC} ×0.3	V	
Permissive input ripple voltage	V _{RF}	—	—	100	mVp-p	
Terminal resistor	R _T	—	100	—	Ω	Differential input
Differential input threshold voltage	High	V _{IH}	—	—	100	mV
	Low	V _{IL}	-100	—	—	mV

【Note1】

On-off sequences of V_{CC} and data

- 0 < t₁ ≤ 15ms
- 0 < t₂ ≤ 50ms
- 0 < t₃ ≤ 50ms
- 1s ≤ t₄

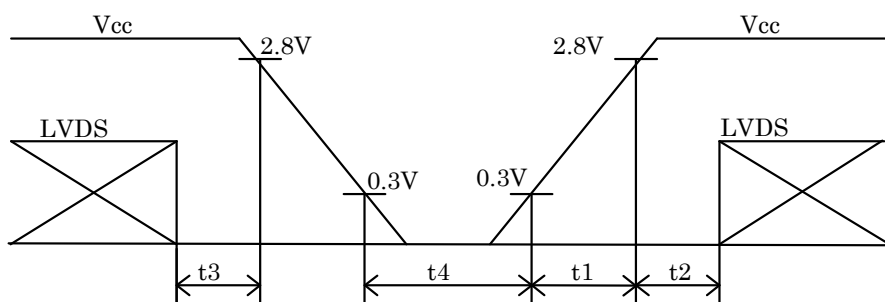

Dip conditions for supply voltage

V_{min}, V_{th} = 3.0V, 2.4V

- 1) V_{th} ≤ V_{CC} < V_{min}
T_d ≤ 10ms
- 2) V_{CC} < V_{th}

V_{CC}-dip conditions should also follow the on-off conditions.

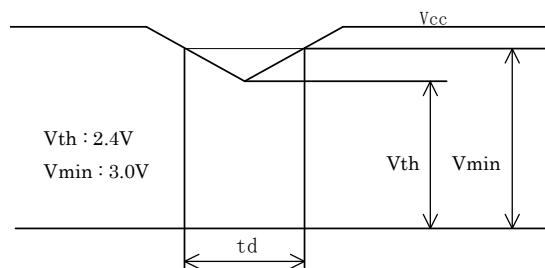

【Note2】 Typical current situation : 64-gray-bar pattern

V_{CC} = +3.3V, f_{ck} = 65MHz, Ta = 25°C

The explanation of each gray scale is described below section 14.

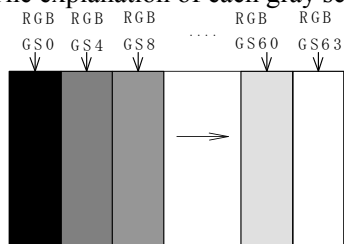

When VS(V63) and V0 stripe pattern are displayed alternately at intervals of two lines.

(The explanation of each gray scale is described below section 14.)

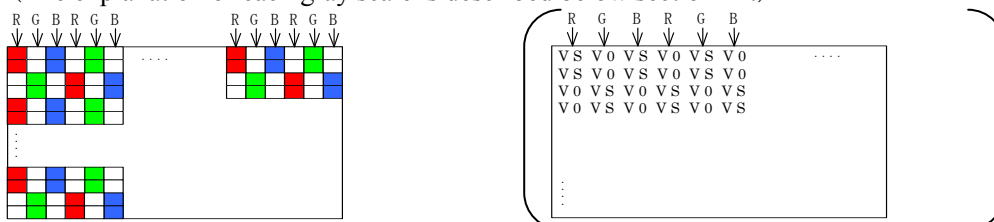

【Note3】 Terminal : REV

6-2. Backlight

The backlight system is an edge-lighting type with two CCFTs (Cold Cathode Fluorescent Tube).

The characteristics of single lamp are shown in the following table.

※Recommended inverter(TDK : CXA-0463)

Ta=25°C

Parameter	Symbol	Min.	Typ.	Max.	Unit	Remarks
Lamp voltage	VL	380	420	460	V rms	IL=6mA rms
Lamp current	IL	3.0	6.0	6.5	mA rms	[Note6-7]
Lamp power consumption	PL	-	2.5	-	W	
Lamp frequency	fL	50	-	80	KHz	Recommend 55kHz
Kick-off voltage [Note6-1]	Vs	-	-	890	V rms	Ta=25°C [Note6-8]
		-	-	1070		Ta=-30°C [Note6-8]
Lamp life time	LL	-	50,000	—	hour	[Note6-9]

[Note6-7] Lamp current is measured with current meter for high frequency as shown below.

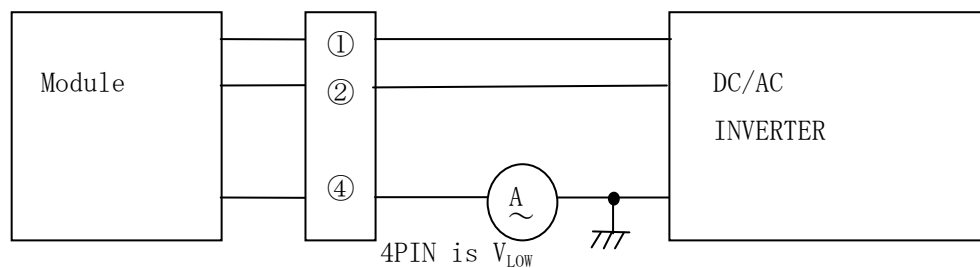

[Note6-8] The open output voltage of the inverter shall be maintained for more than 1sec;

otherwise the lamp may not be turned on.

The input voltage wave forms to terminal ① and terminal ② should be in a same phase. It has the possibility to discharge abnormally between the terminals in case of input of a reversed phase.

For the sake of the safety, please so design the inveter as to prevent abnormal discharge when one of the two lamps is broken or reaches the end of life.

[Note6-9] The data for lamp is for your reference, because lamp is consumable component.

a) Lamp life time is defined by either 1or 2 below. (Continuous turning on at Ta=25°C, IL=6mA rms)

① When a brightness of lamp surface became 50% of the initial value under the standard condition.

②When a kick-off voltage in Ta= -30°C exceeded maximum value ((1070) Vrms) at the output of inverter circuitry

b) In case of operating under lower temp. environment, the lamp exhaustion is accelerated and the brightness becomes lower.

(Continuous operating for around 1 month under lower temp. condition may reduce the brightness to half of the original brightness.)

In case of such usage under lower temp. environment, periodical lampexchange is recommended

[Note] The performance of the backlight, for example life time or brightness, is much influenced by the characteristics of the DC-AC inverter for the lamp. When you design or order the inverter, please make sure that an inadequate lighting caused by the mismatch of the backlight and the inverter (miss-lighting, flicker, etc.) never occur. When you confirm it, the module should be operated in the same condition as it is installed in your instrument.

7. Timing characteristics of input signals

7-1-1. Timing characteristics

Parameter	Symbol	Min.	Typ.	Max.	Unit	Remark
Frequency	1/Tc	35	40	42	MHz	
Horizontal period	TH	832	1056	1395	clock	
		20.8	26.4	39.9	μs	
Horizontal period (High)	THd	800	800	800	clock	
Vertical period	TV	628	666	798	line	【Note】
		-	17.6	-	ms	
Vertical period (High)	TVd	600	600	600	line	

【Note1】 In case of using the long vertical period, the deterioration of display quality, flicker etc. may occur.

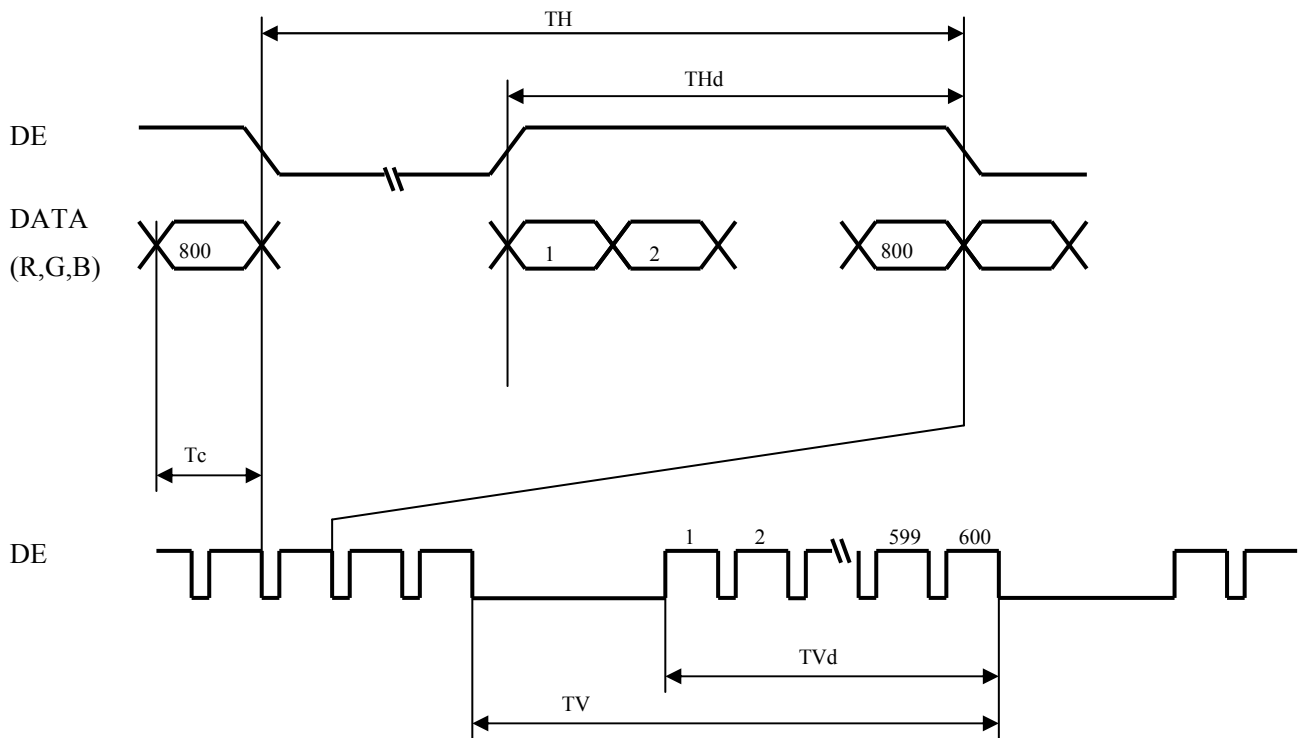

7-2 Input Data Signals and Display Position on the screen

Graphics and texts can be displayed on a panel with 16M colors by supplying 24 bit data signal (8bit/color [253 gray scales] × 3).

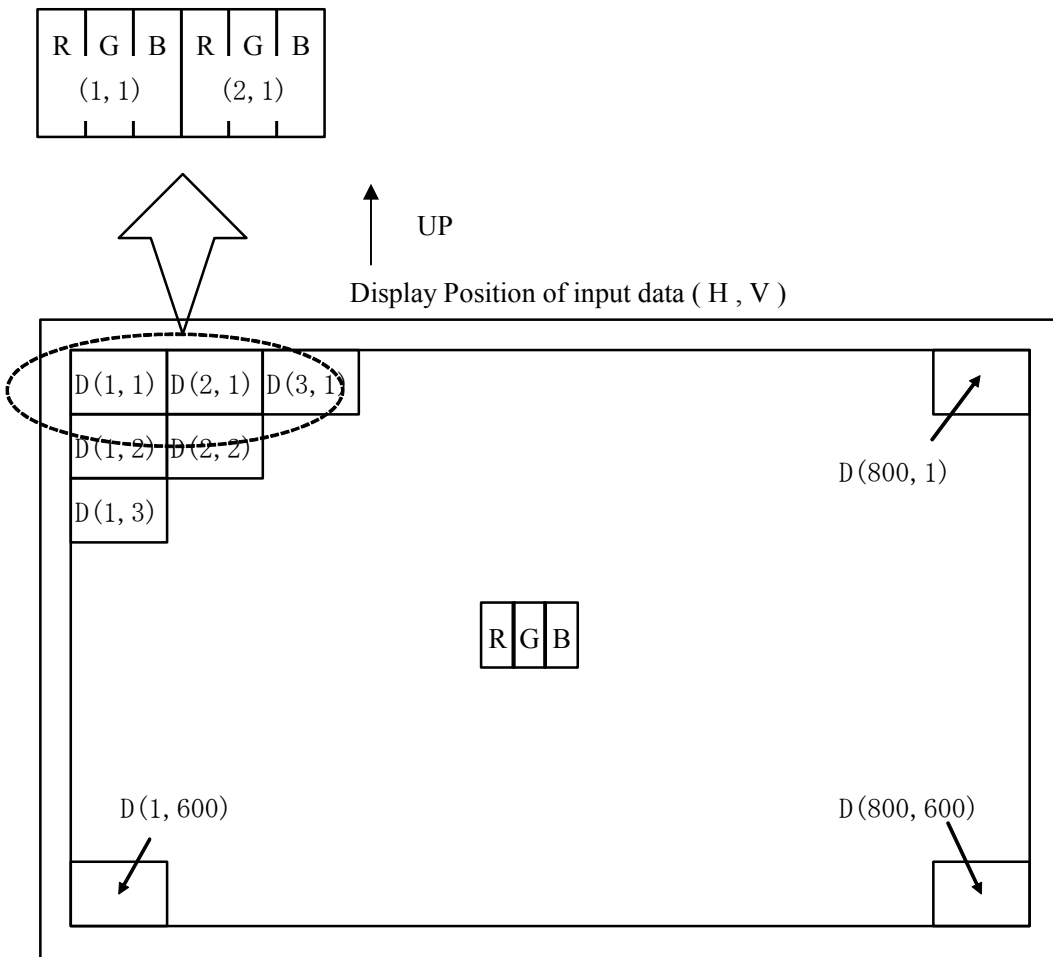

8. Input Signals, Basic Display Colors and Gray Scale of Each Color

	Colors & Gray scale	Gray Scale	Data signal																							
			R0	R1	R2	R3	R4	R5	R6	R7	G0	G1	G2	G3	G4	G5	G6	G7	B0	B1	B2	B3	B4	B5	B6	B7
Basic Color	Black	—	0	0	0	0	0	0	0	0	0	0	0	0	0	0	0	0	0	0	0	0	0	0	0	0
	Blue	—	0	0	0	0	0	0	0	0	0	0	0	0	0	0	0	0	X	X	1	1	1	1	1	1
	Green	—	0	0	0	0	0	0	0	0	X	X	1	1	1	1	1	1	0	0	0	0	0	0	0	0
	Cyan	—	0	0	0	0	0	0	0	0	X	X	1	1	1	1	1	1	X	X	1	1	1	1	1	1
	Red	—	X	X	1	1	1	1	1	1	0	0	0	0	0	0	0	0	0	0	0	0	0	0	0	0
	Magenta	—	X	X	1	1	1	1	1	1	0	0	0	0	0	0	0	0	X	X	1	1	1	1	1	1
	Yellow	—	X	X	1	1	1	1	1	1	X	X	1	1	1	1	1	1	0	0	0	0	0	0	0	0
	White	—	X	X	1	1	1	1	1	1	X	X	1	1	1	1	1	1	X	X	1	1	1	1	1	1
Gray Scale of Red	Black	GS0	0	0	0	0	0	0	0	0	0	0	0	0	0	0	0	0	0	0	0	0	0	0	0	0
	↑	GS1	1	0	0	0	0	0	0	0	0	0	0	0	0	0	0	0	0	0	0	0	0	0	0	0
	Darker	GS2	0	1	0	0	0	0	0	0	0	0	0	0	0	0	0	0	0	0	0	0	0	0	0	0
	↑	↓					↓							↓								↓				
	↓	↓					↓							↓								↓				
	Brighter	GS250	1	0	0	1	1	1	1	1	0	0	0	0	0	0	0	0	0	0	0	0	0	0	0	0
	↓	GS251	1	1	0	1	1	1	1	1	0	0	0	0	0	0	0	0	0	0	0	0	0	0	0	0
	Red	GS252	X	X	1	1	1	1	1	1	0	0	0	0	0	0	0	0	0	0	0	0	0	0	0	0
Gray Scale of Green	Black	GS0	0	0	0	0	0	0	0	0	0	0	0	0	0	0	0	0	0	0	0	0	0	0	0	0
	↑	GS1	0	0	0	0	0	0	0	0	1	0	0	0	0	0	0	0	0	0	0	0	0	0	0	0
	Darker	GS2	0	0	0	0	0	0	0	0	0	1	0	0	0	0	0	0	0	0	0	0	0	0	0	0
	↑	↓					↓							↓								↓				
	↓	↓					↓							↓								↓				
	Brighter	GS250	0	0	0	0	0	0	0	0	1	0	0	1	1	1	1	1	0	0	0	0	0	0	0	0
	↓	GS251	0	0	0	0	0	0	0	0	1	1	0	1	1	1	1	1	0	0	0	0	0	0	0	0
	Green	GS252	0	0	0	0	0	0	0	0	X	X	1	1	1	1	1	1	0	0	0	0	0	0	0	0
Gray Scale of Blue	Black	GS0	0	0	0	0	0	0	0	0	0	0	0	0	0	0	0	0	0	0	0	0	0	0	0	0
	↑	GS1	0	0	0	0	0	0	0	0	0	0	0	0	0	0	0	0	1	0	0	0	0	0	0	0
	Darker	GS2	0	0	0	0	0	0	0	0	0	0	0	0	0	0	0	0	0	1	0	0	0	0	0	0
	↑	↓					↓							↓								↓				
	↓	↓					↓							↓								↓				
	Brighter	GS250	0	0	0	0	0	0	0	0	0	0	0	0	0	0	0	0	1	0	0	1	1	1	1	1
	↓	GS251	0	0	0	0	0	0	0	0	0	0	0	0	0	0	0	0	1	1	0	1	1	1	1	1
	Blue	GS252	0	0	0	0	0	0	0	0	0	0	0	0	0	0	0	0	X	X	1	1	1	1	1	1

0 : Low level voltage, 1 : High level voltage. X :Don't care.

Each basic color can be displayed in 253 gray scales from 8 bit data signals. According to the combination of total 24 bit data signals, the 16M color display can be achieved on the screen.

9. Optical Characteristics

Ta=25°C, Vcc =+3.3V

Parameter		Symbol	Condition	Min.	Typ.	Max.	Unit	Remark
Viewing angle range	Horizontal	$\theta 21$	$CR \geq 10$	50	65	-	Deg.	【Note1,4】
		$\theta 22$		50	65	-	Deg.	
	Vertical	$\theta 11$		40	55	-	Deg.	
		$\theta 12$		45	60	-	Deg.	
Contrast ratio		CR	the best viewing angle	400	600	-	-	【Note2,4】
Response time	rise	τr	$\theta = 0^\circ$	-	5	15	ms	【Note3,4】
	fall	τd		-	21	40	ms	
Chromaticity of White		X	$\theta = 0^\circ$	0.263	0.313	0.363	-	【Note4,5】
		Y		0.279	0.329	0.379	-	
Luminance of white		YL	$\theta = 0^\circ$	320	400	-	cd/m ²	
Direction of the best viewing angle		-			6		o'clock	【Note6】

※The measurement shall be executed 30 minutes after lighting at rating. (IL = 6mArms×2)

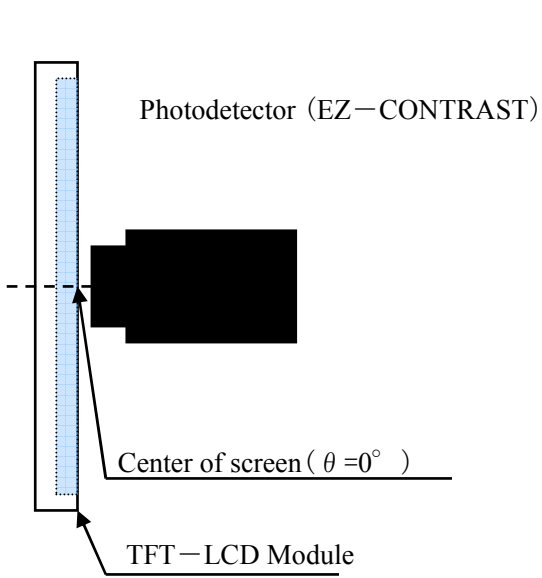

Fig2-1 Viewing angle measurement method

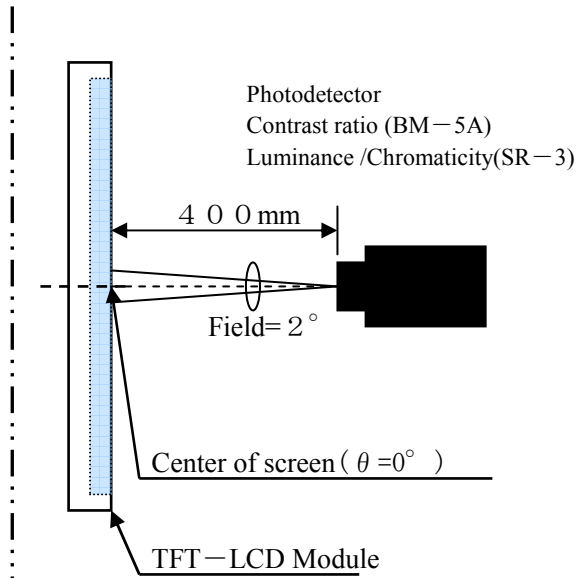
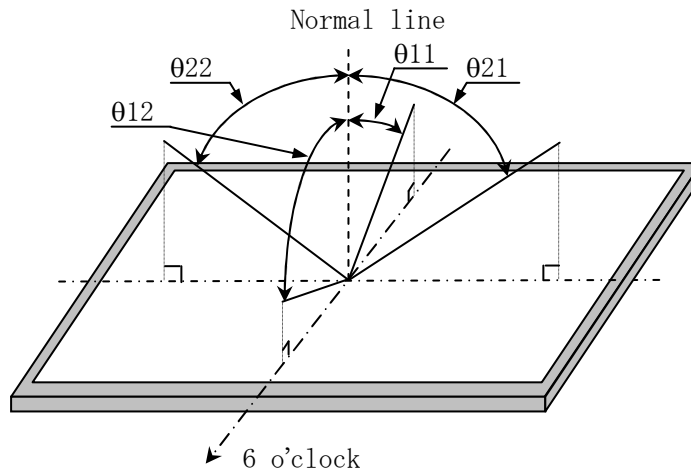

Fig2-2 Luminance/Contrast ratio/Response time/Chromaticity measurement method

Fig2 Optical characteristics measurement method

【Note1】 Definitions of viewing angle range:



The best viewing angle of this module is slightly leaned to 6 o'clock from normal line. In the field where θ_{12} exceeds this angle, gray-scale is reversed partially. The gray-scale in the field of 12 o'clock direction is brighter than that of 6 o'clock direction and isn't reversed.

【Note2】 Definition of contrast ratio:

The contrast ratio is defined as the following.

$$\text{Contrast Ratio (CR)} = \frac{\text{Luminance (brightness) with all pixels white}}{\text{Luminance (brightness) with all pixels black}}$$

【Note3】 Definition of response time:

The response time is defined as the following figure and shall be measured by switching the input signal for "black" and "white".

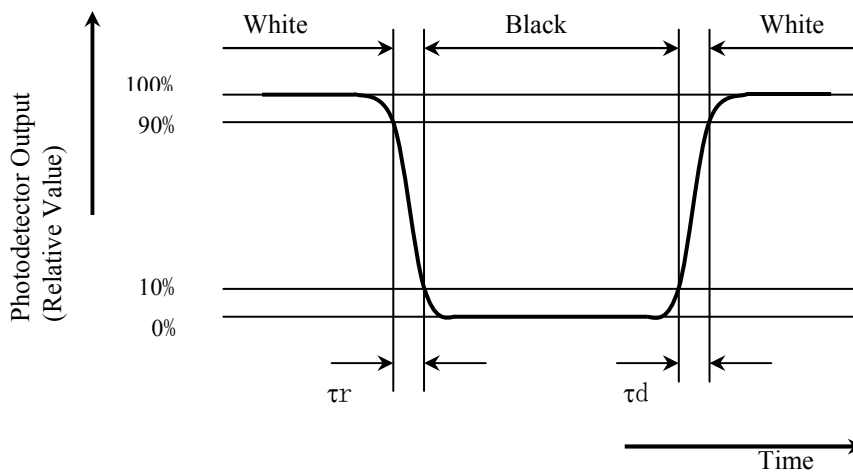

【Note4】 This shall be measured at center of the screen.

10. Handling Precautions

- a) Be sure to turn off the power supply when inserting or disconnecting the cable.
- b) Be sure to design the cabinet so that the module can be installed without any extra stress such as warp or twist.
- c) Since the front polarize is easily damaged, pay attention not to scratch it.
- d) Since long contact with water may cause discoloration or spots, wipe off water drop immediately.
- e) When the panel surface is soiled, wipe it with absorbent cotton or other soft cloth.
- f) Since the panel is made of glass, it may break or crack if dropped or bumped on hard surface. Handle with care.
- g) Since CMOS LSI is used in this module, take care of static electricity and take the human earth into consideration when handling.
- h) Make sure the four mounting holes of the module are grounded sufficiently. Take electro-magnetic interference (EMI) into consideration.
- i) The module has some printed circuit boards (PCBs) on the back side. Take care to keep them form any stress or pressure when handling or installing the module; otherwise some of electronic parts on the PCBs may be damaged.
- j) Observe all other precautionary requirements in handling components.
- k) Since it is necessary to remove the screw on the back of a module before performing lamp exchange, please take a cabinet design into consideration.
- l) When some pressure is added onto the module from rear side constantly, it causes display non-uniformity issue, functional defect, etc. So, please avoid such design.
- m) When handling LCD modules and assembling them into cabinets, please be noted that long-term storage in the environment of oxidization or deoxidization gas and the use of such materials as reagent, solvent, adhesive, resin, etc. which generate these gasses, may cause corrosion and discoloration of the LCD modules.
- n) The polarizer surface on the panel is treated with Anti-Glare for low reflection. In case of attaching protective board over the LCD, be careful about the optical interface fringe etc. which degrades display quality.

11. Packing form

- a) Maximum number of Carton being stuck: Max. 6 cartons
- b) Maximum number of product contained: 10 Unit
- c) Carton size: 408mm (W) x 203mm (D) x 244mm (H)
- d) Total mass (for 20Unit): 6kg
- e) Fig.3 shows packaging form.

12. Reliability test items

No.	Test parameter	Conditions
1	High temperature storage test	Leaves the module at Ta=80°C for 240h
2	Low temperature storage test	Leaves the module at Ta=-30°C for 240h
3	High temperature & high humidity operation test	Operates the module at Ta=40°C; 95%RH for 240h (No condensation)
4	High temperature operation test	Operates the module with +80°C at panel surface for 240h
5	Low temperature operation test	Operates the module at Ta=-30°C for 240h
6	Vibration test (non- operating)	Frequency : 10~57Hz/Vibration width (one side):0.15mm : 58~500Hz/ acceleration:19.6m/s ² (2G) Sweep time : 11 minutes Test period :1 hour for each direction of X,Y,Z (total 3 hours)
7	Shock test (non- operating)	Max. acceleration : 686m/s ² (70G) Pulse width : 6ms, sine wave Direction : ±X,±Y,±Z once for each direction.

[Result Evaluation Criteria]

Under the display quality test conditions with normal operation state, these shall be no change which may affect practical display function.

13. Others

1) Lot No.label:

SHARP		MADE IN CHINA	
LQD84S3LG01		07G00001 Q A	
COLD CATHODE FLUORESCENT LAMP IN LCD PANEL CONTAINS A SMALL AMOUNT OF MERCURY. PLEASE FOLLOW LOCAL ORDINANCES OR REGULATIONS FOR DISPOSAL. 当該液晶ディスプレイパネルは蛍光管が組み込まれていますので、地方自治体の条例、または、規則に従って廃棄して下さい。			
HIGH VOLTAGE CAUTION		RISK OF ELECTRIC SHOCK DISCONNECT THE ELECTRIC POWER BEFORE SERVICING	

Model name

Country of origin

Revision marks (A, B, C, ...)

Interoffice control code (Q, L, etc.)

Serial No. contents

Production year (ex. 2007 → “07”)

Production month (JAN:A, FEB:B, ..., DEC:L)

Serial number(00001 ~)

- 2) Adjusting volume have been set optimally before shipment, so do not change any adjusted value.
If adjusted value is changed, the specification may not be satisfied.
- 3) Disassembling the module can cause permanent damage and should be strictly avoided.
- 4) Please be careful since image retention may occur when a fixed pattern is displayed for a long time.
- 5) When any question or issue occurs, it shall be solved by mutual discussion.
- 6) Don't use or store the module in corrosive gas environment.
- 7) The LCD has the nature that its performance is degradation by ultra-violet light. Don't leave the LCD module in direct sunlight or strong ultra violet ray. (A fall of the contrast, a shift of the chromaticity)

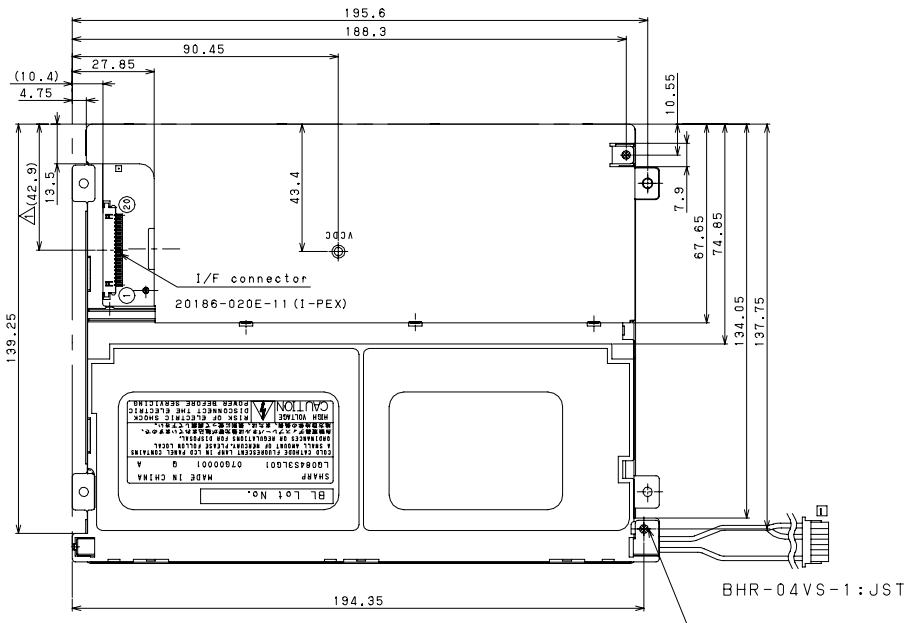
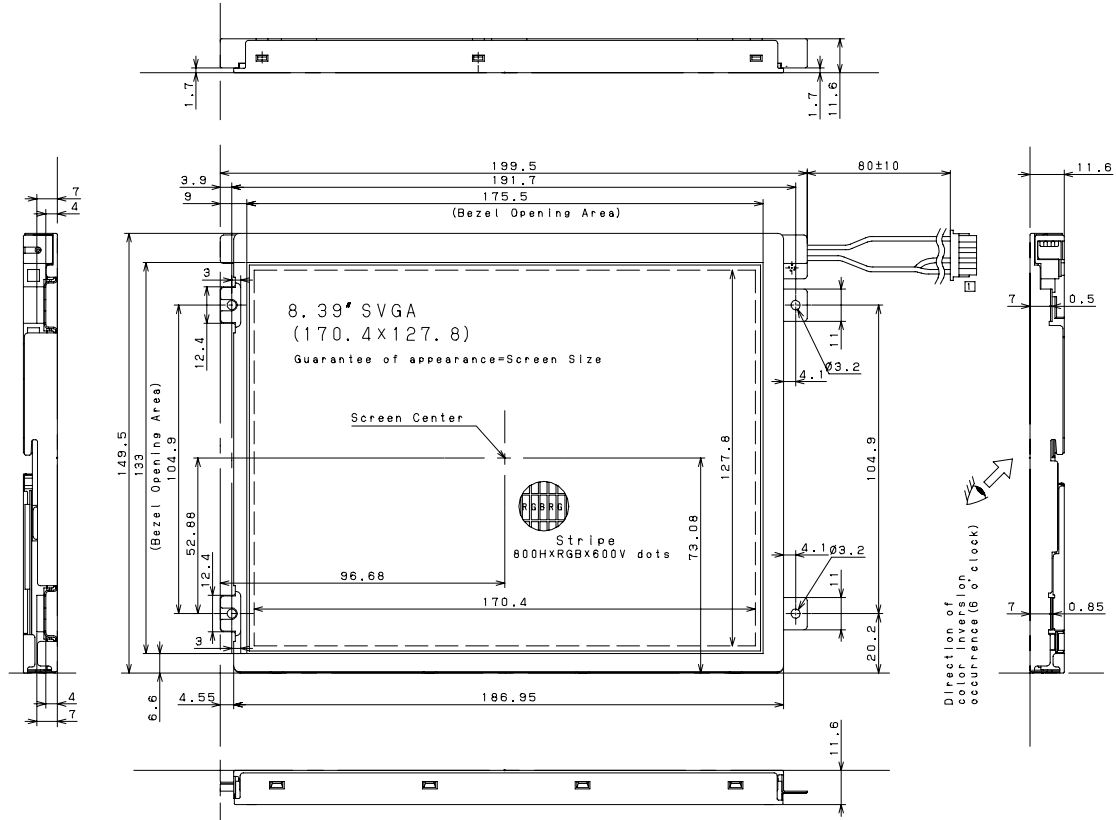

General tolerance is ± 0.5 .

Take care in set design to hide the scratches and bubbles appeared on the polarizer or other frame area which is located outside of active area.

unit:mm	Please do not copy this material and do not disclose this to third party.					
DATE	2007. 07. 26	SCALE	free	No.	DATE	REVISION
MODEL	LQ0184IS3LIG01111					
DRAWING No	L1CM11-1071216A	size	A2	SHARP CO. LTD		ENGINEERING DEPARTMENT MOBILE LCD DIVISION MOBILE LIQUID CRYSTAL DISPLAY GROUP

FIG. 1 OUTLINE DIMENSIONS

SHARP

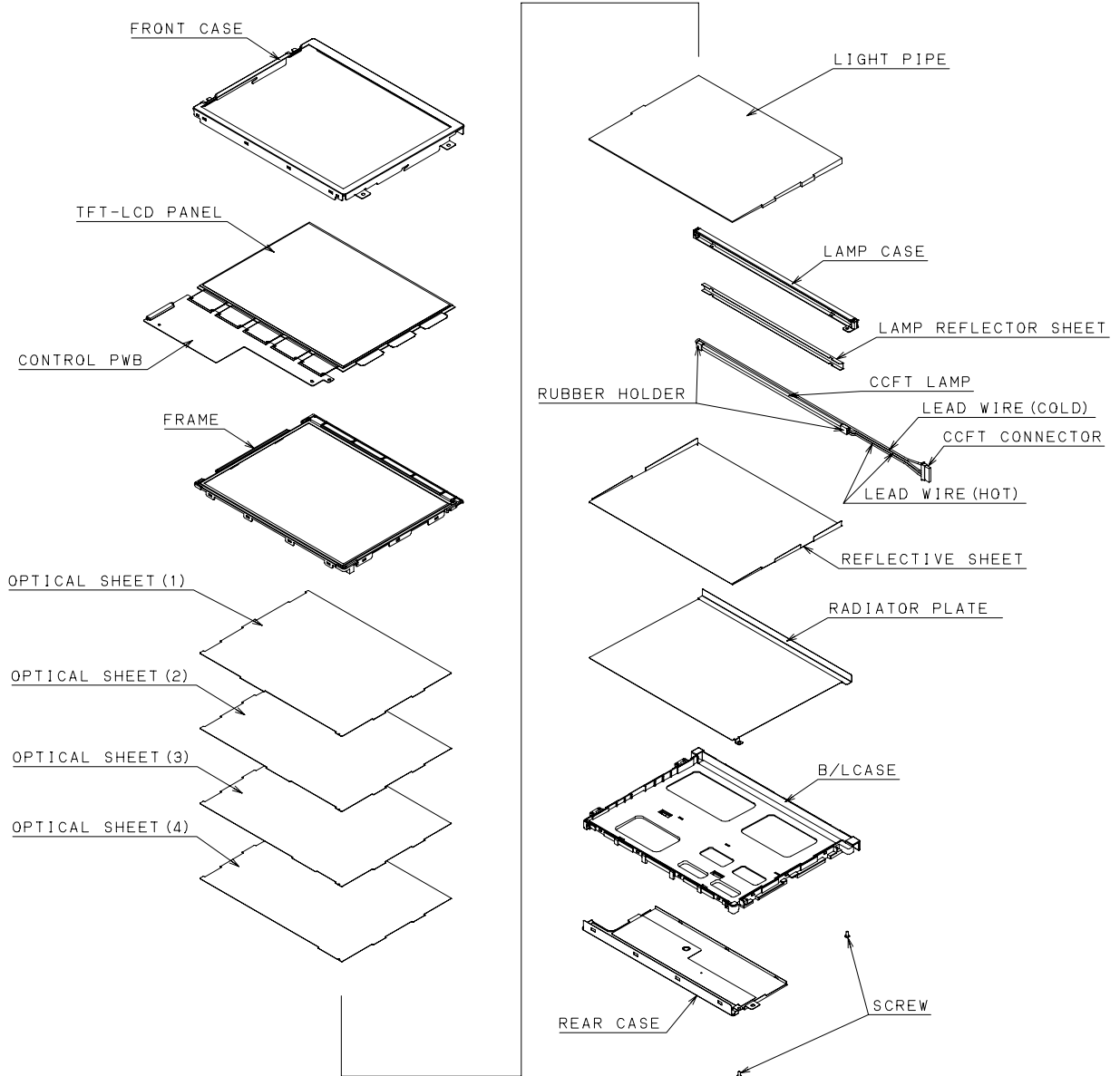

FIG.2 MODULE CONFIGURATION

SHARP[®]

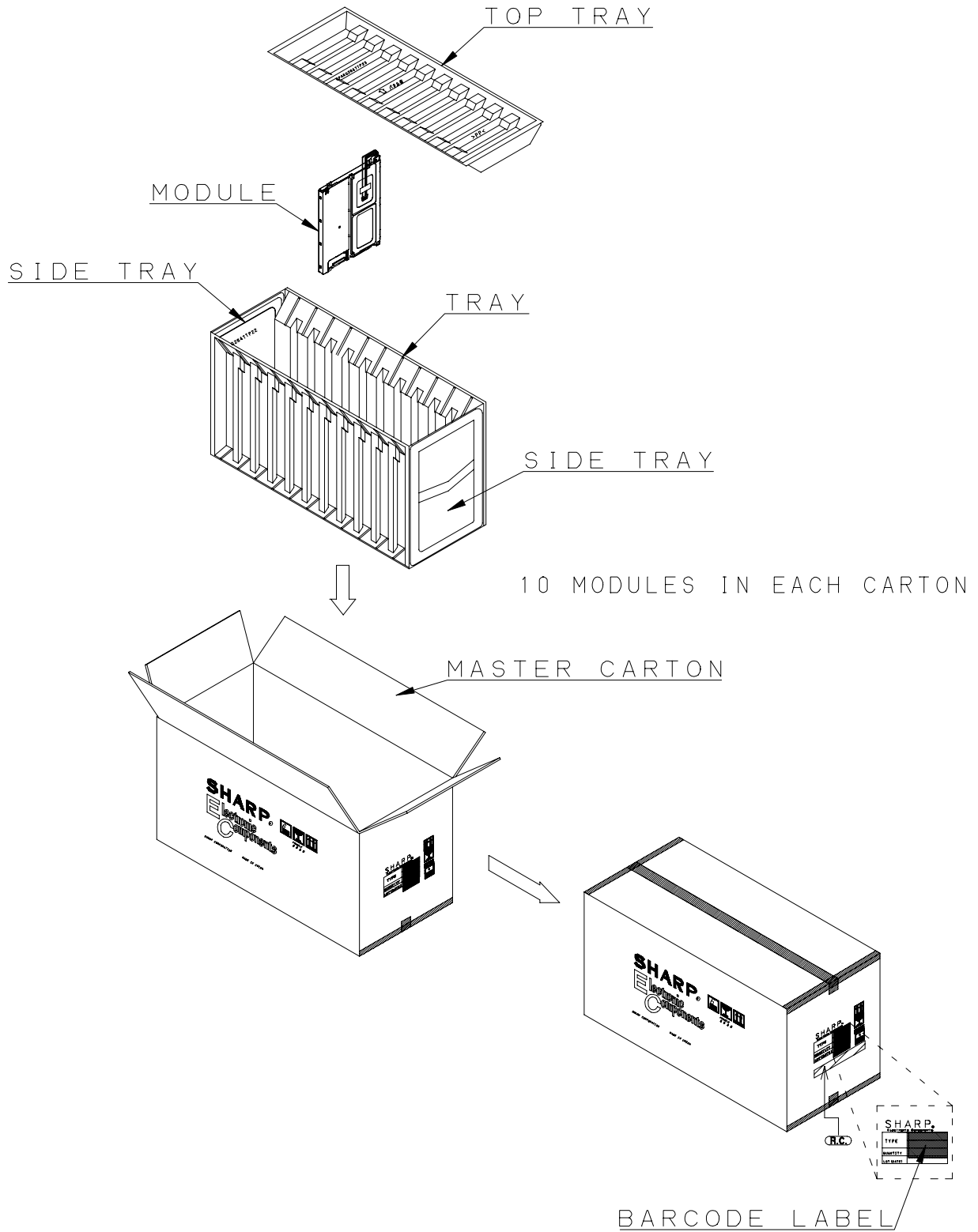

FIG. 3 PACKING FORM

LCD Specification

LCD Group



NORTH AMERICA

Sharp Microelectronics of the Americas
5700 NW Pacific Rim Blvd.
Camas, WA 98607, U.S.A.
Phone: (1) 360-834-2500
Fax: (1) 360-834-8903
www.sharpsma.com

TAIWAN

Sharp Electronic Components
(Taiwan) Corporation
8F-A, No. 16, Sec. 4, Nanking E. Rd.
Taipei, Taiwan, Republic of China
Phone: (886) 2-2577-7341
Fax: (886) 2-2577-7326/2-2577-7328

CHINA

Sharp Microelectronics of China
(Shanghai) Co., Ltd.
28 Xin Jin Qiao Road King Tower 16F
Pudong Shanghai, 201206 P.R. China
Phone: (86) 21-5854-7710/21-5834-6056
Fax: (86) 21-5854-4340/21-5834-6057
Head Office:
No. 360, Bashen Road,
Xin Development Bldg. 22
Waigaoqiao Free Trade Zone Shanghai
200131 P.R. China
Email: smc@china.global.sharp.co.jp

EUROPE

Sharp Microelectronics Europe
Division of Sharp Electronics (Europe) GmbH
Sonninstrasse 3
20097 Hamburg, Germany
Phone: (49) 40-2376-2286
Fax: (49) 40-2376-2232
www.sharpsme.com

SINGAPORE

Sharp Electronics (Singapore) PTE., Ltd.
438A, Alexandra Road, #05-01/02
Alexandra Technopark,
Singapore 119967
Phone: (65) 271-3566
Fax: (65) 271-3855

KOREA

Sharp Electronic Components
(Korea) Corporation
RM 501 Geosung B/D, 541
Dohwa-dong, Mapo-ku
Seoul 121-701, Korea
Phone: (82) 2-711-5813 ~ 8
Fax: (82) 2-711-5819

JAPAN

Sharp Corporation
Electronic Components & Devices
22-22 Nagaïke-cho, Abeno-Ku
Osaka 545-8522, Japan
Phone: (81) 6-6621-1221
Fax: (81) 6117-725300/6117-725301
www.sharp-world.com

HONG KONG

Sharp-Roxy (Hong Kong) Ltd.
3rd Business Division,
17/F, Admiralty Centre, Tower 1
18 Harcourt Road, Hong Kong
Phone: (852) 28229311
Fax: (852) 28660779
www.sharp.com.hk
Shenzhen Representative Office:
Room 13B1, Tower C,
Electronics Science & Technology Building
Shen Nan Zhong Road
Shenzhen, P.R. China
Phone: (86) 755-3273731
Fax: (86) 755-3273735

SPECIFICATIONS ARE SUBJECT TO CHANGE WITHOUT NOTICE.

Suggested applications (if any) are for standard use; See Important Restrictions for limitations on special applications. See Limited Warranty for SHARP's product warranty.

The Limited Warranty is in lieu, and exclusive of, all other warranties, express or implied.

ALL EXPRESS AND IMPLIED WARRANTIES, INCLUDING THE WARRANTIES OF MERCHANTABILITY, FITNESS FOR USE AND FITNESS FOR A PARTICULAR PURPOSE, ARE SPECIFICALLY EXCLUDED. In no event will SHARP be liable, or responsible in any way, for any incidental or consequential economic or property damage.

Mouser Electronics

Authorized Distributor

Click to View Pricing, Inventory, Delivery & Lifecycle Information:

[Sharp Microelectronics:](#)

[LQ084S3LG01](#)