

PREPARED BY : DATE	<h1>SHARP</h1> <p>Mobile Liquid Crystal Display GROUP SHARP CORPORATION</p> <h2>SPECIFICATION</h2>	SPEC No. LD17421
APPROVED BY : DATE		FILE No.
		ISSUE : Apr.20.2005
		PAGE : 35 pages
		APPLICABLE GROUP Mobile Liquid Crystal Display Group

DEVICE SPECIFICATION

TFT-LCD Module

MODEL No.

LQ150X1DWF1

(FLC38XGC6V-06P)

CUSTOMER : _____

CUSTOMER'S APPROVAL

DATE _____

BY _____

PRESENTED
 BY T. Yatsui
 T. Yatsui
 Department general manager
 Product Quality Assurance DEPT. III
 Mobile Liquid Crystal Display Group
 SHARP Corporation

BY T. Naka
 T. Naka
 Division deputy general manager of
 Mobile LCD Design Center III
 Engineering Department II
 Mobile LCD Design Center III
 Mobile Liquid Crystal Display Group
 SHARP Corporation

REVISION HISTORY

Revision	Date	Prepared	Checked		Approved	Summary
01A	Jun.21,2004	M.Nishido	Y.Furukoshi		F.Yamada	1st issue
02A	Apr.20,2005	M.Nishido	T. Ito		F. Yamada	Change manufacture to SHARP.

DOCUMENT CONTROL SECTION

					LQ150X1DWF1 (FLC38XGC6V-06P)			
					LD17421			CUST.
02	20050420	Nishido		T. Ito	Add 02A, Revise P3,6,18,22,23,24,31			
EDIT	DATE	DESIG.	CHECK	APPR.	DESCRIPTION			
DESIG.	20040621	M.Nishido	CHECK	Y.Furukoshi	APPR.	F.Yamada	SHARP CORPORATION	

TABLE OF CONTENTS

A

1.APPLICATIONS 3

2.PRODUCT NAME AND MODEL NUMBER

2-1.Product Name 3

2-2.Model Name 3

3.OVERVIEW 3

4.CONFIGURATION..... 3

5.MECHANICAL SPECIFICATIONS 4

B

6.ABSOLUTE MAXIMUM RATINGS 5

7.RECOMMENDED OPERATING CONDITIONS..... 5

8.ELECTRICAL SPECIFICATIONS 6

9.OPTICAL SPECIFICATIONS..... 8

10.INTERFACE SPECIFICATIONS

10-1.Signal descriptions 13

10-2.Color Data Assignment 14

10-3.Input Signal Timing 15

10-4.Correspondence between Data and Display Position 17

C

10-5.Power Supply Sequence 17

11.BACKLIGHT SPECIFICATIONS

11-1.Pin Configuration for Backlight..... 18

11-2.CCFL 18

11-3.Life..... 18

11-4.Lamp Assembly Set (for Replacement) 18

12.APPEARANCE SPECIFICATIONS

12-1.Zone 19

12-2.Bright Spot..... 19

12-3.Test Condition..... 19

12-4.Standard 19

D

13.ENVIRONMENTAL SPECIFICATIONS 21

14.INDICATIONS 22

15.PACKAGING

15-1.Packaging Specifications 22

15-2.Packaging Method 22

16.WARRANTY 27

17.PRECAUTIONS 27

18.PRECAUTIONS FOR USE 33

19.MISCELLANEOUS..... 33

A

B

C

D

E

DOCUMENT CONTROL SECTION

DATE

						LQ150X1DWF1 (FLC38XGC6V-06P)		
						LD17421	CUST.	
EDIT	DATE	DESIG.	CHECK	APPR.	DESCRIPTION			SHARP CORPORATION
DESIG.			CHECK		APPR.		2 /	

F

1. APPLICATIONS

This specification is applied to the 15.0 in. XGA supported TFT-LCD module.

2. PRODUCT NAME AND MODEL NUMBER

2-1. Product Name : LCD Module

02 2-2. SHARP Model Name : LQ150X1DWF1

2-3. Model Name : FLC38XGC6V-06P

3. OVERVIEW

This LCD module has a TFT active matrix type liquid crystal panel 1024×768 pixels, and diagonal size of 38cm (15.0-inch). This module supports 1024×768 XGA mode (Non-interlace).

This LCD has a digital RGB interface and can display 262,144 colors.

Timing control signal is “Data enable signal : ENAB” only. (Data enable mode)

Even and odd data are transmitted at the same timing in the interface, so data lines are 36. (R, G, B each 6 bit ×2) The signal level of this interface is +3.3V CMOS level or 5V TTL level.

The power supply of this LCD module is +5v DC single.

4. CONFIGURATION

This LCD module consists of a LCD panel, LCD driving circuit, control circuit, interface circuit and backlight unit.

The LCD panel is active matrix TFT type. The LCD driving circuit is integrated in IC chips, which are bonded on plastic wiring film (hereinafter TAB driver-IC), and the output terminals of the IC chips are connected to the LCD panel. The control circuit and the interface circuit are mounted on three kinds of printed circuit board (hereinafter PCB) and the input of the TAB driver-ICs are connected to the PCBs.

With such circuit construction, the image data received by the interface circuit is forwarded to the control circuit and the control circuit modulates the image data to LCD driving signals. The TAB driver ICs buffer the LCD driving signals and output driving voltages to the LCD panel.

These LCD parts such as the LCD panel, the TAB-ICs and the PCBs are assembled together with the backlight module in a plastic case and a metal frame.

Fig.4-1 shows a block diagram of this LCD module.

DOCUMENT CONTROL SECTION

DATE

						LQ150X1DWF1 (FLC38XGC6V-06P)		
						LD17421		CUST.
02	20050420				Change Model Name			
EDIT	DATE	DESIG.	CHECK	APPR.	DESCRIPTION			
DESIG.			CHECK		APPR.		SHARP CORPORATION	
							Sheet	3 /

A

A

B

B

C

C

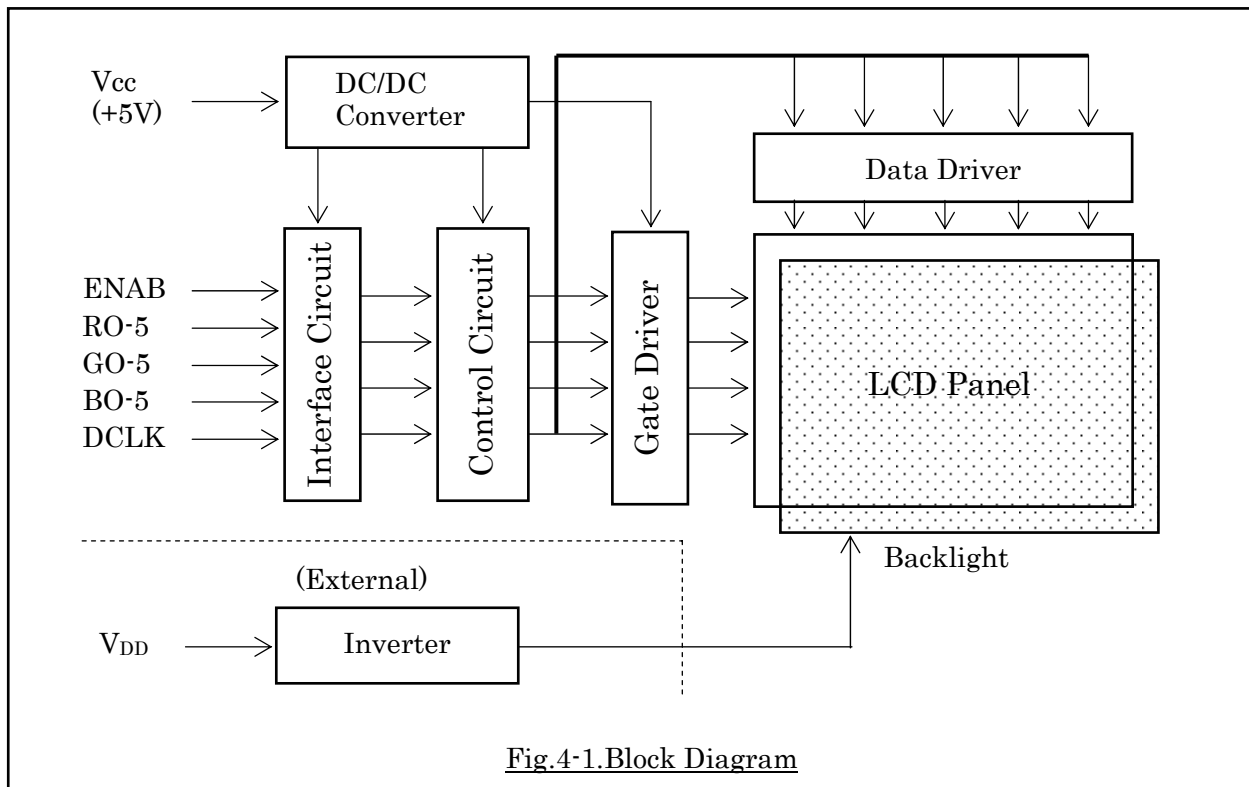

Fig.4-1. Block Diagram

5. MECHANICAL SPECIFICATIONS

Table 5-1 shows the mechanical specifications of this LCD module.

D

Table 5-1. Mechanical Specifications

Item	Specifications	Unit	Remark
Dimensions	347.3×263.5×15.8(TYP.) (Excluding I/F Connector and fixing parts)	mm	Edge type backlight is used. (φ2.6 CCFL×4) Outward Appearance is shown at page 34 and 35.
Display Resolution	(1024×3) ×768	—	
Display Dot Area	304.1×228.1	mm	
Dot Pitch	(0.099×3) ×0.297	mm	
Aspect Ratio	1 : 1	—	
Weight	1,600max	g	
FG-SG	Short circuit	—	

D

E

DOCUMENT CONTROL SECTION

DATE

						LQ150X1DWF1 (FLC38XGC6V-06P)	
						LD17421	
						CUST.	
EDIT	DATE	DESIG.	CHECK	APPR.	DESCRIPTION		
DESIG.			CHECK		SHARP CORPORATION		
						4 /	

F

A

A

6. ABSOLUTE MAXIMUM RATINGS

Table 6-1 shows the absolute maximum rating of this LCD module.

Table 6-1. Absolute Maximum Ratings

Item	Symbol	Condition	MIN.	TYP.	MAX.	Unit
Supply Voltage	V _{CC}	Ta=25°C	-0.3	—	6.0	V
Input Voltage	V _{IN}	Ta=25°C	-0.3	—	V _{CC} +0.3	V

B

B

7. RECOMMENDED OPERATING CONDITIONS

Table 7-1 shows the recommended operating conditions of this LCD module.

Table 7-1. Recommended Operating Conditions

Item	Symbol	MIN.	TYP.	MAX.	Unit
Supply Voltage (Logic)	V _{CC}	4.75	5.0	5.25	V
Ripple Voltage	V _{CC} V _{RP}	—	—	100	mV

C

C

D

D

DOCUMENT CONTROL SECTION

DATE

E

F

						LQ150X1DWF1 (FLC38XGC6V-06P)	
						LD17421	
						CUST.	
EDIT	DATE	DESIG.	CHECK	APPR.	DESCRIPTION		
DESIG.			CHECK		SHARP CORPORATION		
						5 /	

8. ELECTRICAL SPECIFICATIONS

Table 8-1 shows the electrical specifications of this LCD module.

Table 8-1. Electrical Specifications

Item	Symbol	Condition	MIN.	TYP.	MAX.	Unit	Remark
Supply Current	I _{CC}	V _{CC} =+5.0±0.25V V _{SS} =0V	—	380	800	mA	*1
“H” Level Logic Input Voltage	V _{IH}	DCLK=32.505MHz	2.3	—	V _{CC}	V	
“L” Level Logic Input Voltage	V _{IL}		V _{SS}	—	0.9	V	
Leak Current (Logic Input)	I _{IL}		-5	—	+5	µA	
Supply Rush Current	I _{SCC}		—	—	5.5	A	*2
Supply Rush Current Duration (1A excess)	T _{SCC}		—	—	0.4	ms	
BACK LIGHT	CCFL Turn on Voltage	V _S f _L =50kHz, Ta=25°C	—	1324	1500	Vrms	
		f _L =50kHz, Ta=0°C	—	—	1500		
	Lighting Voltage	V _L f _L =50kHz I _L =7mA	550	580	610	Vrms	
	Lighting Frequency	f _L V _L =580Vrms	40	50	60	kHz	
*4	Tube Current	I _L f _L =50kHz V _L =580Vrms	6	7	8	mA	*4

(*1) Typical current value is measured when color bar pattern is displayed at V_{CC}=5.0V. Maximum current value is measured when 55/63 and 63/63 gray scale pattern every 2 pixel is displayed at V_{CC}=4.75V. Without rush current.

(*2) These items prescribe the rush current for starting internal DC/DC. Charging current to capacitors of V_{CC} is not prescribed.

(*3) Backlight specifications are valid when using a suitable inverter such as the “LQ0DDJ5004 (FLCV-07)” of Sharp .



(*4) Tube current (I_L) shows the value of the current that is consumed at one lamp. This LCD module has 4 lamps. Each 2 lamps are placed at upper and lower side of the display. 2 lamps are connected in parallel. Each low voltage terminals are bound into 1 line cable, which connected to the backlight connector.

DOCUMENT CONTROL SECTION

DATE

						LQ150X1DWF1 (FLC38XGC6V-06P)	
						LD17421	
02	20050420			Change Inverter Model Name		CUST.	
EDIT	DATE	DESIG.	CHECK	APPR.	DESCRIPTION	SHARP CORPORATION	
		DESIG.	CHECK	APPR.	6 /		

Note 1) Measurement Circuit

Based on Fig.8-1.

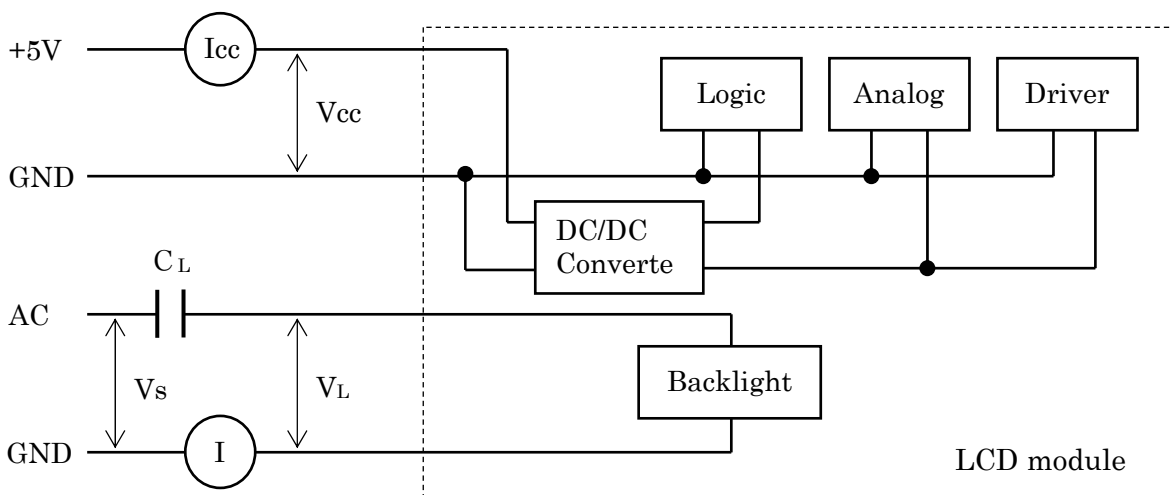
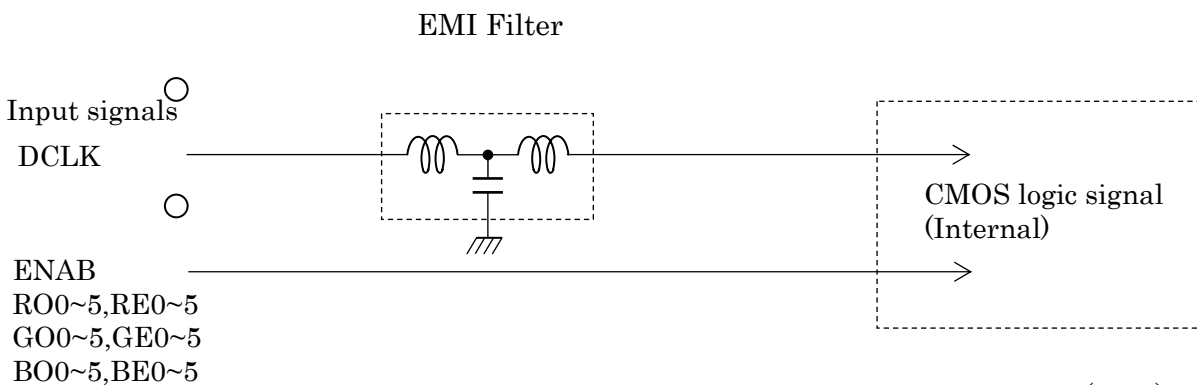

Fig.8-1. Measurement Circuit

Note 2) Equivalent Circuit

Based on Fig.8-2 (a), (b).



EMI Filter.....MEM2012TC100(TDK)

Fig.8-2 (a) Equivalent Circuit of Logic Signal Input

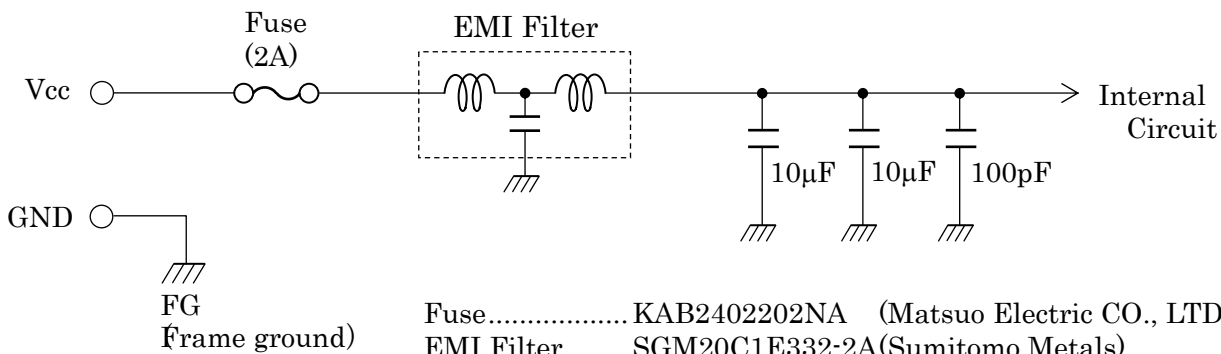

Fuse.....KAB2402202NA (Matsuo Electric CO., LTD.)
EMI Filter.....SGM20C1E332-2A(Sumitomo Metals)

Fig.8-2 (b) Equivalent Circuit of Power Supply

DOCUMENT CONTROL SECTION

DATE

						LQ150X1DWF1 (FLC38XGC6V-06P)	
						LD17421	
						CUST.	
EDIT	DATE	DESIG.	CHECK	APPR.	DESCRIPTION		
DESIG.			CHECK		SHARP CORPORATION		
							7 /

9. OPTICAL SPECIFICATIONS

Table 9-1 shows the optical specifications of this LCD module.

Table 9-1. Optical Specifications

Ta=25°C, Signal timing=Typ.

Item	Symbol	Condition	Specifications			Unit	Remark			
			MIN.	TYP.	MAX.			Note		
Visual Angle	Horizontal	$\theta_{L,R}$	$CR \geq 10$	$\theta_{U,D}=0^\circ$	80	—	—	deg	(1)(2)	
	Vertical	$\theta_{U,D}$		$\theta_{L,R}=0^\circ$	80	—	—	deg	(3)(5)(6)	
Contrast Ratio	CR	$\theta_{L,R,U,D}=0^\circ$		210	400	—	—	White/Black	(1)(2)(3)(5)	
Response Time(ON) (Black→White)	t_{on}	$\theta_{L,R,U,D}=0^\circ$	Ta=25°C	—	15	30	ms		(1)(4)(5)	
			Ta=0°C	—	50	100	ms			
Response Time(OFF) (White→Black)	t_{off}	$\theta_{L,R,U,D}=0^\circ$	Ta=25°C	—	10	25	ms			
			Ta=0°C	—	50	100	ms			
Brightness	I	$\theta_{L,R,U,D}=0^\circ$ VCC=5V, IL=7mA fL=50kHz R*,G*,B*Signal =All"H"		200	250	—	cd/m ²	White*1	(1)(5)	
Brightness Uniformity	ΔI			80	—	—	%		(1)(5)(7)	
Chromaticity	W			x	0.283	0.313	0.343	—		(1)(5)
				y	0.299	0.329	0.359	—		
	R			x		(0.637)				
				y		(0.352)				
	G			x		(0.281)				
		y		(0.604)						
B	x		(0.145)							
	y		(0.126)							
LCD Panel Type				TFT Color						
Display Mode				Normally Black VA						
Wide Viewing Angle Technology				MVA						
Optimum Viewing Angle				— (symmetry)					(6)	
Display Color				262,144 (6-bit color)						
Color of non-display area				Black						
Surface Treatment				Anti-glare(Haze value : 25%,2H)						

(*1) Value at 15~20 minutes after lighting on.

(Note) •CS-1000 (MINOLTA Co., Ltd.) Field=1°, L=500mm

•Back-light current = 7mA, Dark room condition(1 lux or less)

Be carefull that the luminance meter, which you use, may not be able to get correct brightenss if it's no set correctly.

DOCUMENT CONTROL SECTION

DATE

				LQ150X1DWF1 (FLC38XGC6V-06P)					
				LD17421				CUST.	
EDIT	DATE	DESIG.	CHECK	APPR.	DESCRIPTION				SHARP CORPORATION
DESIG.			CHECK		APPR.				
								8 /	

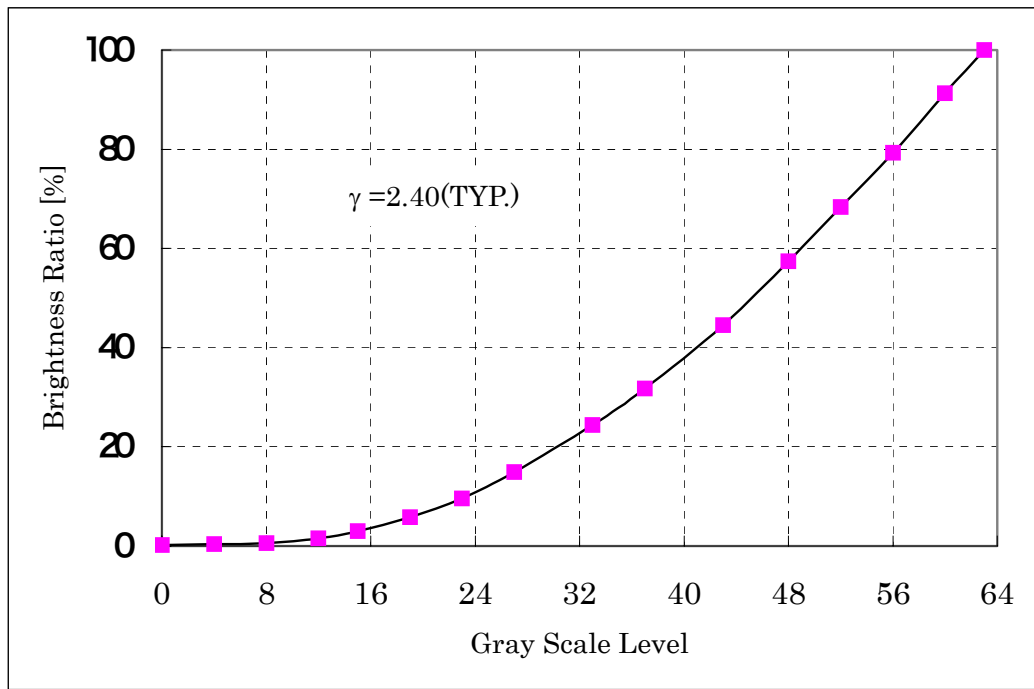

Fig.9-1. γ -Curve (Reference Value)

DATE	
DOCUMENT CONTROL SECTION	

						LQ150X1DWF1 (FLC38XGC6V-06P)	
						LD17421	CUST.
EDIT	DATE	DESIG.	CHECK	APPR.	DESCRIPTION		SHARP CORPORATION
DESIG.			CHECK		APPR.		
							9 /

A

Note 1) Definition of Viewing Angle (1)

Based on Fig.9-2.

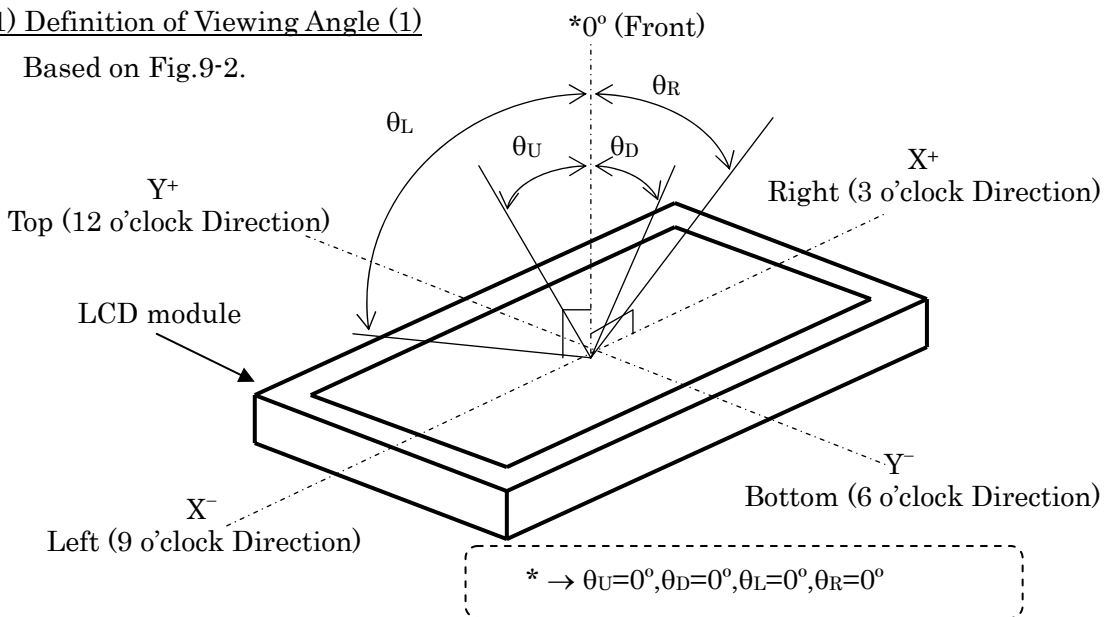

Fig.9-2. Definition of Viewing Angle (1)

C

Note 2) Definition of Viewing Angle (2)

Based on Fig.9-3.

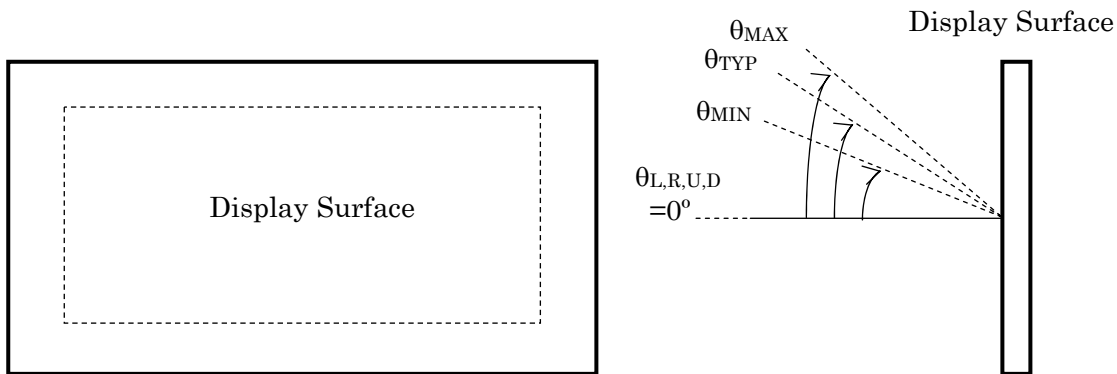

Fig.9-3. Definition of Viewing Angle (2)

D

Note 3) Definition of Contrast Ratio (CR)

Determined by Formula (1) based on Fig.9-4.Voltage-Brightness Characteristics.

$$= \frac{L_W \text{ (Brightness at white)}}{L_B \text{ (Brightness at black)}} \dots\dots (1)$$

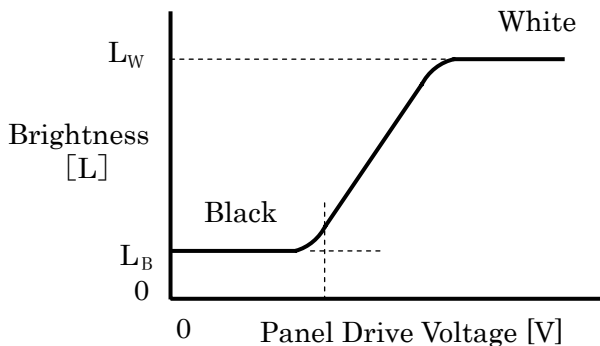

Fig.9-4. Voltage-Brightness Characteristics

DOCUMENT CONTROL SECTION

DATE

						LQ150X1DWF1 (FLC38XGC6V-06P)			
						LD17421		CUST.	
EDIT	DATE	DESIG.	CHECK	APPR.	DESCRIPTION				
DESIG.			CHECK		APPR.			SHARP CORPORATION	
								Stack	10/

A

B

C

D

E

F

Note 4) Definition of Response Time

Based on Fig.9-5.

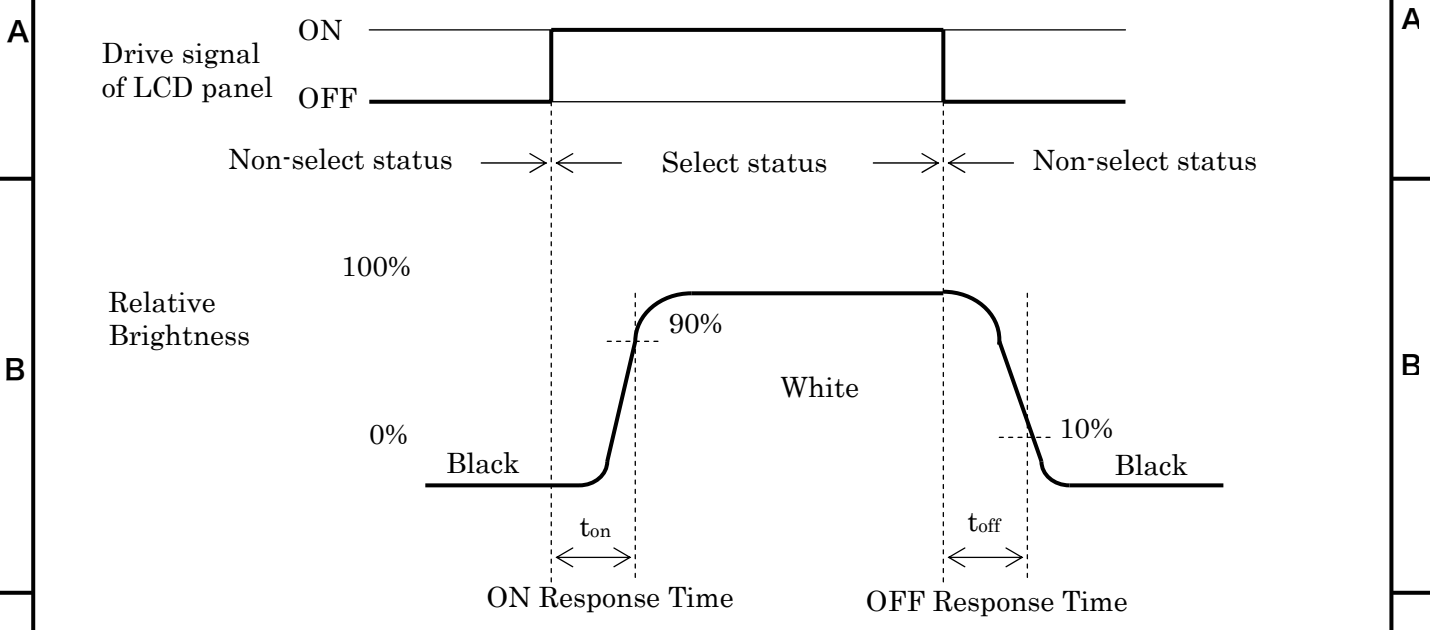

Fig.9-5. Definition of Response Time

Note 5) Contrast Ratio and Response Measurement System

Based on Fig.9-6.

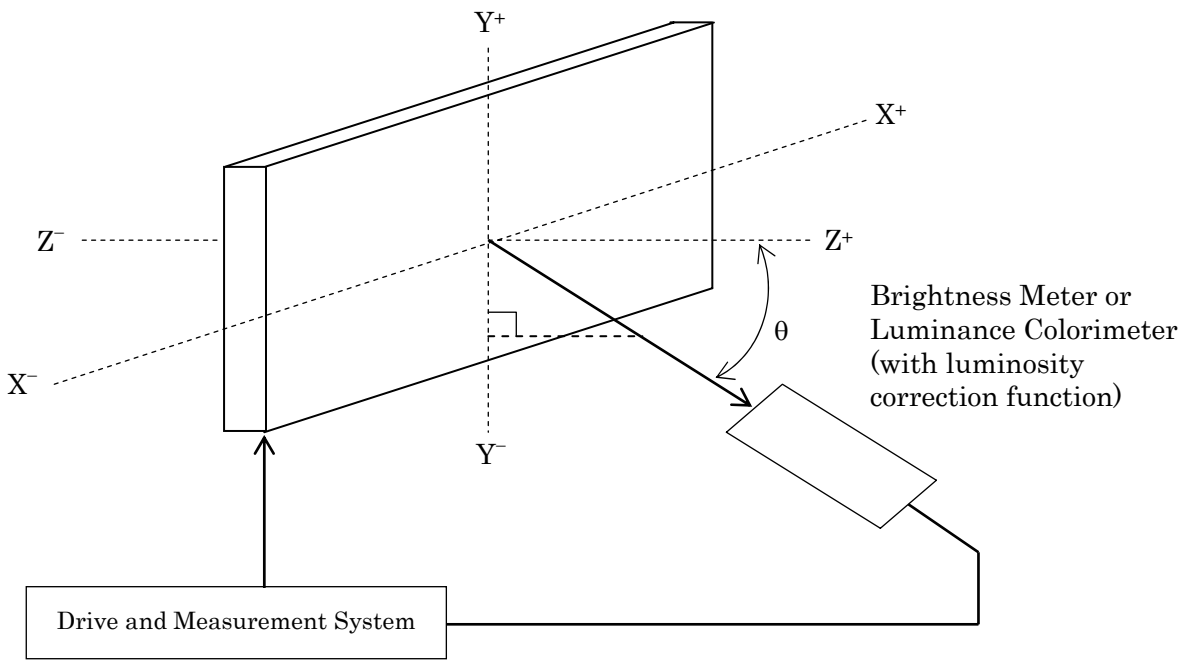

Fig.9-6. Contrast Ratio and Response Time Measurement System

DOCUMENT CONTROL SECTION	
DATE	

						LQ150X1DWF1 (FLC38XGC6V-06P)		
						LD17421		CUST.
EDIT	DATE	DESIG.	CHECK	APPR.	DESCRIPTION			SHARP CORPORATION
DESIG.			CHECK		APPR.		11 /	

Note 6) Definition of Optimum Viewing Angle

Based on Fig.9-7.

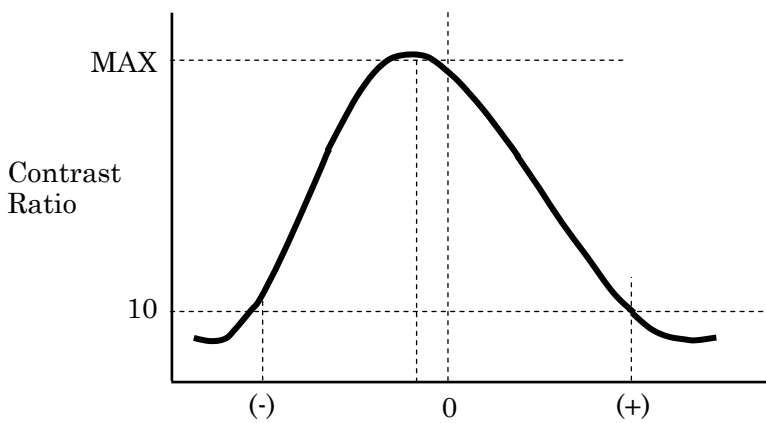

6 o'clock ← Viewing Angle θ → 12 o'clock

Fig.9-7. Definition of Viewing Angle

Note 7) Definition of Brightness Uniformity

Brightness uniformity is defined by the following formula.

Brightness (I1~I9) are measured at the following 9 points (① ~ ⑨) on the display area shown in Fig.9-8.

$$\text{Brightness Uniformity } (\Delta L) = \frac{|\text{Min. In}|}{|\text{Max. In}|} \times 100 (\%), n=1 \text{ to } 9$$

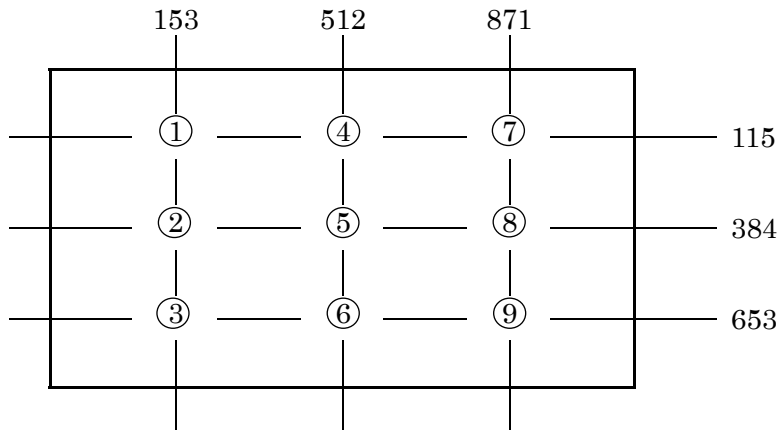

Note) Each measurement point (① ~ ⑨) defines the center spot of Brightness Meter view. The tolerance of measurement position is $\pm 5\text{mm}$.

Fig.9-8. Measurement Points

DOCUMENT CONTROL SECTION

DATE

						LQ150X1DWF1 (FLC38XGC6V-06P)	
						LD17421	
						CUST.	
EDIT	DATE	DESIG.	CHECK	APPR.	DESCRIPTION		
DESIG.			CHECK		SHARP CORPORATION		
							12/

10. INTERFACE SPECIFICATIONS

10-1. Signal descriptions

Table 10-1 shows the description and configuration of Interface signals (CN1).

Table 10-1. Interface signals (CN1)

Pin No.	Symbol	I/O	Function	Pin No.	Symbol	I/O	Function
1	GND	—	Ground	31	GO1	I	Green odd data 1
2	RE0	I	Red even data 0	32	GO2	I	Green odd data 2
3	RE1	I	Red even data 1	33	GO3	I	Green odd data 3
4	RE2	I	Red even data 2	34	GO4	I	Green odd data 4
5	RE3	I	Red even data 3	35	GO5	I	Green odd data 5
6	RE4	I	Red even data 4	36	GND	—	Ground
7	RE5	I	Red even data 5	37	BO0	I	Blue odd data 0
8	GND	—	Ground	38	BO1	I	Blue odd data 1
9	GE0	I	Green even data 0	39	BO2	I	Blue odd data 2
10	GE1	I	Green even data 1	40	BO3	I	Blue odd data 3
11	GE2	I	Green even data 2	41	BO4	I	Blue odd data 4
12	GE3	I	Green even data 3	42	BO5	I	Blue odd data 5
13	GE4	I	Green even data 4	43	GND	—	Ground
14	GE5	I	Green even data 5	44	PULL	I	(*2)
15	GND	—	Ground	45	PULL	I	(*2)
16	BE0	I	Blue even data 0	46	ENAB	I	Data enable signal
17	BE1	I	Blue even data 1	47	GND	—	Ground
18	BE2	I	Blue even data 2	48	GND	—	Ground
19	BE3	I	Blue even data 3	49	DCLK	I	Dot clock signal
20	BE4	I	Blue even data 4	50	GND	—	Ground
21	BE5	I	Blue even data 5	51	GND	—	Ground
22	GND	—	Ground	52	SS	—	SS function ON/OFF (*1)
23	RO0	I	Red odd data 0	53	N.C.	—	—
24	RO1	I	Red odd data 1	54	GND	—	Ground
25	RO2	I	Red odd data 2	55	GND	—	Ground
26	RO3	I	Red odd data 3	56	GND	—	Ground
27	RO4	I	Red odd data 4	57	VDD	—	+5V Power supply
28	RO5	I	Red odd data 5	58	VDD	—	+5V Power supply
29	GND	—	Ground	59	VDD	—	+5V Power supply
30	GO0	I	Green odd data 0	60	VDD	—	+5V Power supply

(*1) SS (Spread Spectrum):SS function is ON when signal level is high or N.C..(generally set up N.C.)
 SS function is OFF when signal level is low.

(*2).Connect it to GND for the protection of internal circuit.

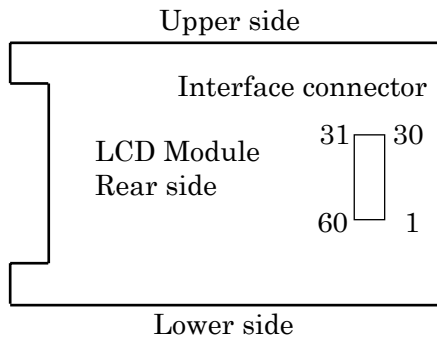

Connector : 52760-0600 (Molex)
 User's connector : 53475-0600 (Molex)

(*3)When using a connector other than the recommended one , a defect in the initial stage or a problem concerning long term reliability may occur.

DOCUMENT CONTROL SECTION

DATE

					LQ150X1DWF1 (FLC38XGC6V-06P)	
					LD17421	
					CUST.	
EDIT	DATE	DESIG.	CHECK	APPR.	DESCRIPTION	
DESIG.			CHECK		SHARP CORPORATION	
					13/	

10-2. Color Data Assignment

Table 10-2 shows the color data assignment.

Table 10-2. Color Data Assignment

Color	R Input data						G Input data						B Input data						
	Odd Even	R05 RE5	R04 RE4	R03 RE3	R02 RE2	R01 RE1	R00 RE0	G05 GE5	G04 GE4	G03 GE3	G02 GE2	G01 GE1	R00 GE0	B05 BE5	B04 BE4	B03 BE3	B02 BE2	B01 BE1	B00 BE0
Basic Color	Black	0	0	0	0	0	0	0	0	0	0	0	0	0	0	0	0	0	0
	Blue	0	0	0	0	0	0	0	0	0	0	0	0	1	1	1	1	1	1
	Green	0	0	0	0	0	0	1	1	1	1	1	1	0	0	0	0	0	0
	Cyan	0	0	0	0	0	0	1	1	1	1	1	1	1	1	1	1	1	1
	Red	1	1	1	1	1	1	0	0	0	0	0	0	0	0	0	0	0	0
	Magenta	1	1	1	1	1	1	0	0	0	0	0	0	1	1	1	1	1	1
	Yellow	1	1	1	1	1	1	1	1	1	1	1	1	1	1	1	1	1	1
	White	1	1	1	1	1	1	1	1	1	1	1	1	0	0	0	0	0	0
Red	Black	0	0	0	0	0	0	0	0	0	0	0	0	0	0	0	0	0	0
	↑	1	0	0	0	0	0	0	0	0	0	0	0	0	0	0	0	0	0
	↑	
	↓	
	Brighter	61	1	1	1	1	0	0	0	0	0	0	0	0	0	0	0	0	0
	↓	62	1	1	1	1	1	0	0	0	0	0	0	0	0	0	0	0	0
Red	63	1	1	1	1	1	0	0	0	0	0	0	0	0	0	0	0	0	
Green	Black	0	0	0	0	0	0	0	0	0	0	0	0	0	0	0	0	0	0
	↑	1	0	0	0	0	0	0	0	0	0	0	1	0	0	0	0	0	0
	↑	
	↓	
	Brighter	61	0	0	0	0	0	1	1	1	1	0	1	0	0	0	0	0	0
	↓	62	0	0	0	0	0	1	1	1	1	1	0	0	0	0	0	0	0
Green	63	0	0	0	0	0	1	1	1	1	1	1	0	0	0	0	0	0	
Blue	Black	0	0	0	0	0	0	0	0	0	0	0	0	0	0	0	0	0	0
	↑	1	0	0	0	0	0	0	0	0	0	0	0	0	0	0	0	0	1
	↑	
	↓	
	Brighter	61	0	0	0	0	0	0	0	0	0	0	0	1	1	1	1	0	1
	↓	62	0	0	0	0	0	0	0	0	0	0	0	1	1	1	1	1	0
Blue	63	0	0	0	0	0	0	0	0	0	0	0	1	1	1	1	1	1	

Note.1) Definition of gray scale : Color (n) ---"n" indicates gray scale level.

The gray scale is brighter as the number is larger.

Note.2) Data: 1: High, 0: Low

Note.3) Color data consist of 36 bits, namely, 6-bit odd and even data for each red, green and blue. Optional data can be set to red, green and blue independently. Therefore, the module is able to display 262,144 colors.

DOCUMENT CONTROL SECTION

DATE

						LQ150X1DWF1 (FLC38XGC6V-06P)					
						LD17421			CUST.		
EDIT	DATE	DESIG.	CHECK	APPR.	DESCRIPTION					SHARP CORPORATION	
DESIG.			CHECK			APPR.			14/		

10-3. Input Signal Timing

Table 10-3 and Fig.10-3 shows the input signal timing.

Table 10-3. Timing Characteristics

(T=0~50°C, Vcc=5±0.25V)

Item		Symbol	Min.	Typ.	Max.	Unit	Remark	
DCLK signal (Clock)	Period	Tc	25.000	30.764	40.000	ns	fc=1/Tc *1	
	Frequency	fc	25.000	32.505	40.000	MHz		
	Duty	Tch/Tc	45	50	55	%		
	High time	TclkH	5.0	—	—	ns		
	Low time	TclkL	5.0	—	—	ns		
	Rise time	Tclkr	—	—	5.0	ns		
	Fall time	Tclkf	—	—	5.0	ns		
DCLK-Data Timing	Setup time	Tset	4.5	—	—	ns	40MHz	
	Hold time	Thold	6.5	—	—	ns	40MHz	
Data-ENAB timing	Horizontal	Period	Th	565	672	1566	DCLK	fh=1/Th
		Frequency	fh	38.6	48	60	kHz	
		Display period	Thd	—	512	—	DCLK	*2,3
	Vertical	Period	Tv	772	806	868	Th	16.67ms
		Frequency	fv	50	60	75	Hz	
		Display period	Tvd	—	768	—	Th	*2,3
Data-ENAB timing		—	—	0	—	DCLK	*4	

*1) DCLK signal input must be valid while power supply is applied.

*2) Display position is specified by the ENAB signal.

Horizontal display position is specified by the rise of ENAB signal. The data of a horizontal line, which is latched by the falling edge of 1st DCLK right after the rise of ENAB, is displayed on the left edge of the screen.

Vertical display position is specified by the rise of ENAB after a "Low" level period equivalent to eight times of horizontal period. The 1st data corresponding to one horizontal line after the rise of ENAB is displayed at the top line of screen.

*3) If a period of ENAB "High" is less than 512 DCLK or less than 768 lines, the rest of the screen displays black.

*4) The display position does not fit to the screen if the ENAB period and the effective data period do not synchronize with each other.

DOCUMENT CONTROL SECTION

DATE

						LQ150X1DWF1 (FLC38XGC6V-06P)		
						LD17421		CUST.
EDIT	DATE	DESIG.	CHECK	APPR.	DESCRIPTION			SHARP CORPORATION
DESIG.			CHECK	APPR.			15/	

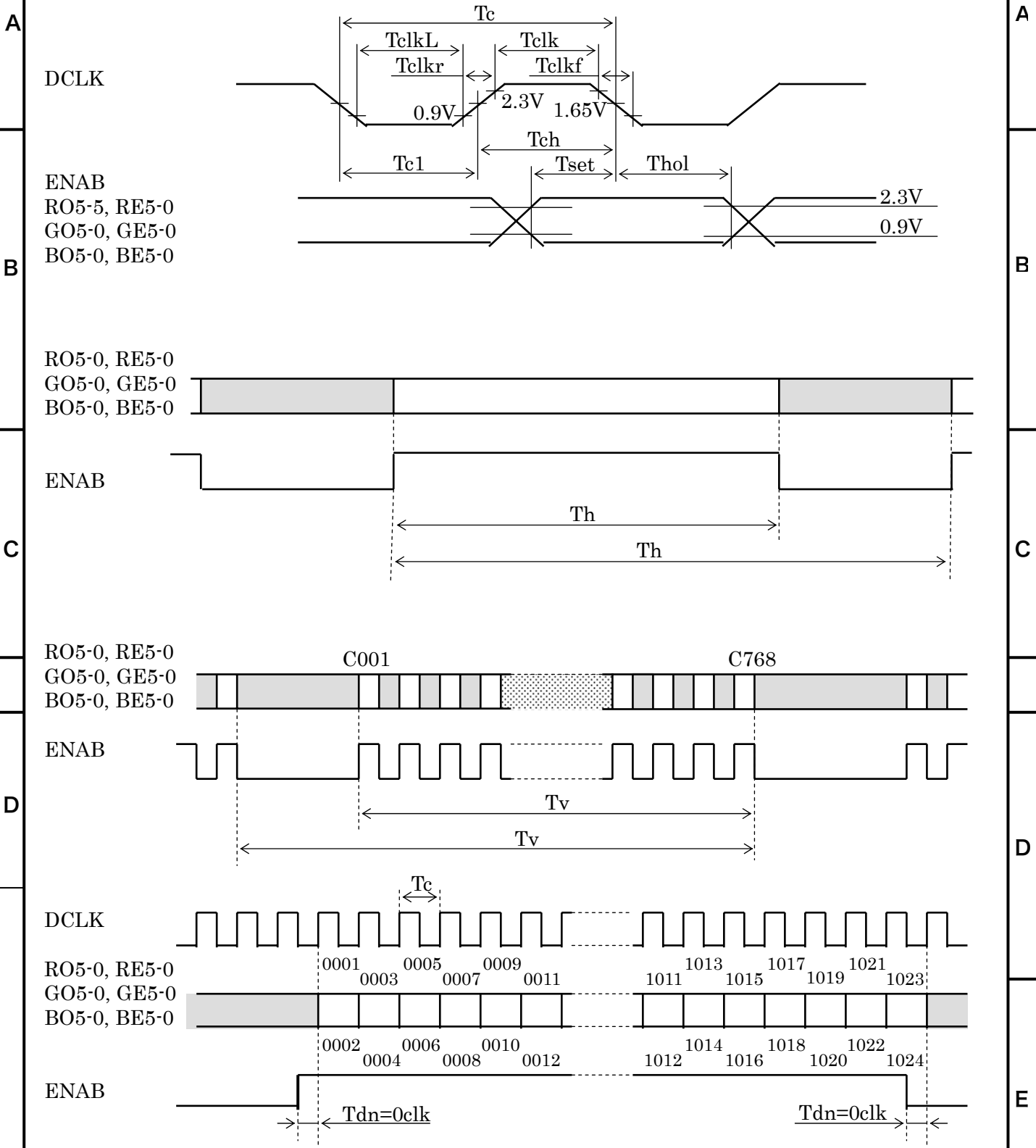

Fig.10-3.Input Signal Timing Chart

DOCUMENT CONTROL SECTION

DATE

						LQ150X1DWF1 (FLC38XGC6V-06P)	
						LD17421	
						CUST.	
EDIT	DATE	DESIG.	CHECK	APPR.	DESCRIPTION	SHARP CORPORATION	
DESIG.			CHECK	APPR.		16/	

10-4. Correspondence between Data and Display Position

Fig.10-3 shows the Correspondence between Data and Display Position.

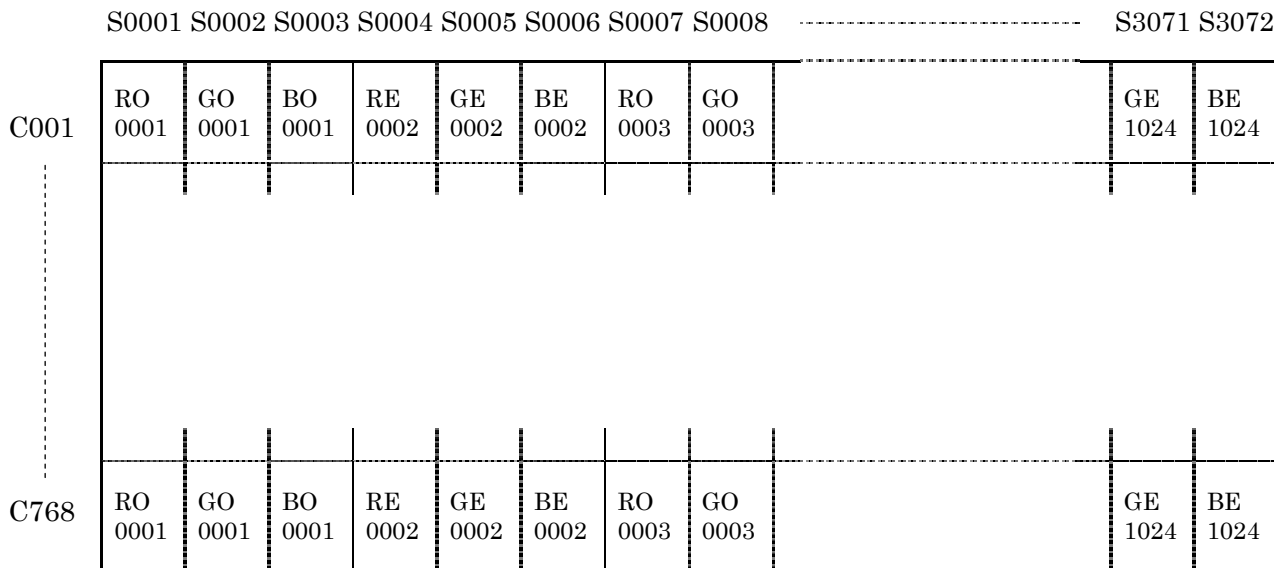

Fig.10-4. Correspondence Data and Display Position

10-5. Power Supply Sequence

The sequence of input signals and On/Off of the power supply of this LCD module should be in the specification shown in Fig.10-4 to prevent latch-up of the driver ICs and DC driving of the LCD panel.

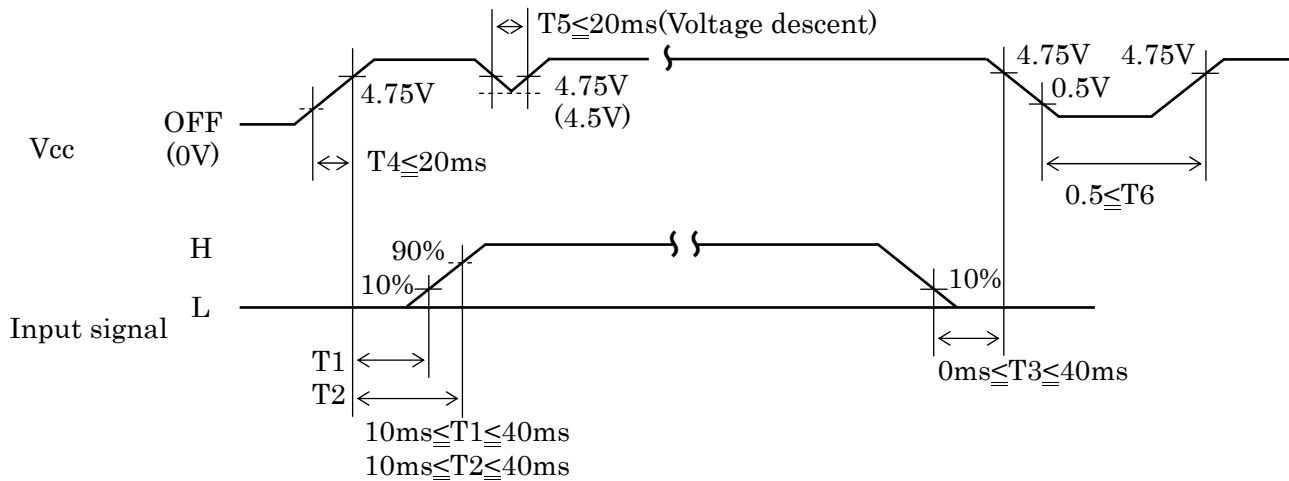

Fig.10-5. Power Supply Sequence

DOCUMENT CONTROL SECTION

DATE

						LQ150X1DWF1 (FLC38XGC6V-06P)			
						LD17421		CUST.	
EDIT	DATE	DESIG.	CHECK	APPR.	DESCRIPTION				
DESIG.			CHECK		APPR.	SHARP CORPORATION			17/

11. BACKLIGHT SPECIFICATIONS

11-1. Pin Configuration for Backlight

Table 11-1(a) and 11-1(b) shows the description and pin assignment of the connectors (CN-A and B) for the Backlight of this LCD module.

Table 11-1(a) Pin Assignment of CN-A

Pin No.	Signal	Function
1	V _{L1}	Power supply for CCFL 1
2	V _{L2}	Power supply for CCFL 2
3	NC	---
4	GND	Ground (for V _{L1} , 2)

Table 11-1(b) Pin Assignment of CN-B

Pin No.	Signal	Function
1	V _{L3}	Power supply for CCFL 3
2	V _{L4}	Power supply for CCFL 4
3	NC	---
4	GND	Ground (for V _{L3} , 4)

Cable color (CN-A and B) : White at GND, Pink at V_{L1},2,3 and 4

Connector : Housing : BHR-04VS-1
 : Contact : SBH-001T-P0.5
 User's Connector : Post with base : SM04(4.0)B-BHS-1-TB
 Supplier : Japan Solderless Terminal Trading Company LTD. (J.S.T.)

11-2. CCFL

Supplier : SANKEN ELECTRIC CO., LTD Part No. KFN8319F315296Z

11-3. Life

The life of the backlight is a minimum of 50,000 hours at the following conditions.

(1) Working conditions

- ① Ambient temperature : 25±5°C
- ② Tube current(I_L) : (7mA or less)

(2) Definition of life

- ① Brightness becomes 50% or below 50% of the minimum brightness value shown in Table 9-1.
- ② The lamp cannot be lit by the breakdown voltage of 1500V_{vms}.
- ③ Lamp is flashing.

11-4. Lamp Assembly set (for replacement)

Lamp Assembly set (with charge) is prepared for maintenance.
This set consists of an upper lamp assembly and a lower lamp assembly.



Type number : LQ0DDB5462 (FLCL-16S) for upper and lower

DOCUMENT CONTROL SECTION

DATE

						LQ150X1DWF1 (FLC38XGC6V-06P)	
						LD17421	
02 20050420						Change Lamp Assembly set No	
EDIT	DATE	DESIG.	CHECK	APPR.	DESCRIPTION		CUST.
DESIG.		CHECK		APPR.		SHARP CORPORATION	
							18/

12. APPEARANCE SPECIFICATIONS

12-1. Zone

- Inside display dot area (304.1× 228.1mm)
- Display dot area means active area.
- One pixel consists of 3 dots (red, green and blue).
- Foreign particle and scratch unharful to display image, such as the foreign particle under polarizer film but outside of the display area and scratch or stain on metal bezel, backlight module, aluminum chassis or polarizer film out of the display area, etc., are not counted.

12-2. Bright spots

- (1) Bright spots by the defect of TFT.
 - Visible under bias of 2% ND filter High bright spot R•G
 - Visible under 5% but invisible under 2% ND filter Low bright spot R•G•B
 - Invisible under bias of 5% ND filter..... Not counted
- (2) Bright spots by the light passing through tears, breaks, etc in color filter.
 - Exceed size of a half dot High bright spot
 - A half dot or less Not counted
- (3) Bright spots by the light passing through tears, breaks, etc in chromium mask.
 - Exceed 50µm High bright spot
 - 50µm or less Not counted

12-3. Test condition

- Inspector must observe the LCD screen from the normal direction under the illumination by a single 20W fluorescent lamp. The distance between the LCD screen and the inspector should be a height of 50cm above the worktable.
- The vertical illuminance is 300 to 600lux (reference value).
- Bright spot should be counted under entire black screen.
- Dark spot should be counted under entire white screen.
- Frame frequency should be 60Hz.

12-4. Specifications

Table 12-4 shows the appearance standard.

(Note1) Please do not mistake a single bright spot for a bright spot connection due to Cs(supplemental capacitance) line at the center of each dot.

(Note2) If a pixel is dark partially, it connects into the number of dark spots in accordance with following rule.

- (a) $S < 1/3$: Not count. Only one of 4 dark connection is allowed.
- (b) $1/3 \leq S < 2/3$: Considered as 0.5 dot.
- (c) $2/3 \leq S$: Considered as 1 dot.

(S=Dark spot size/dot size)

DOCUMENT CONTROL SECTION

DATE

D

A

B

D

E

F

						LQ150X1DWF1 (FLC38XGC6V-06P)		
						LD17421		CUST.
EDIT	DATE	DESIG.	CHECK	APPR.	DESCRIPTION		SHARP CORPORATION	19 /
DESIG.			CHECK		APPR.			

Table 12-4. Appearance specifications

No.	Item		Judgment method and standard		
1	Bright spot (high and Low)		≤ 3 dots (Note 1)		
2	Bright spot connection (high and low)		≤ 1 pair (2 dot connection in horizontal only) (Note 1)		
3	Total of bright spot		≤ 3 dots		
4	Dark spot		≤ 6 dots (Note 2)		
5	Dark spot connection		≤ 3 pairs (2 dot connection in horizontal only) (Note 2)		
6	Total of dark spot		≤ 6 dots (Note 2)		
7	Total of dot defect (bright and dark)		≤ 6 dots		
8	Distance of bright spot	high-high	≥ 15 mm		
		others	≥ 5 mm		
9	Distance of dark spot		≥ 5 mm		
10	Scratch on polarizer, line shape	$W \leq 0.03$		-----	Ignore
		$0.03 < W \leq 0.05$	$L \leq 6$		Ignore
			$6 < L \leq 12$	≤ 3	
		$0.05 < W \leq 0.15$	$12 < L$		0
			$L \leq 0.6$	Ignore	
			$0.6 < L \leq 5$	≤ 2	
		$0.15 < W \leq 0.3$	$5 < L$		0
			$W \times L \leq 0.4$	≤ 1	
$0.3 < W$	$0.4 < W \times L$		0		
	-----		0		
11	Dent on polarizer, dot shape	$D \leq 0.2$		Ignore	
		$0.2 < D \leq 0.4$		≤ 4	
		$0.4 < D$		0	
12	Bubble in polarizer	$D \leq 0.4$		≤ 4	
		$0.4 < D$		0	
13	Black white spot (Foreign circular matter)	$D \leq 0.5$		≤ 4	
		$0.5 < D$		0	
14	Light leakage by foreign articles	$S < 1/3$	1dot		Ignore
			Consecutive 2~3 dots		≤ 3
			Consecutive 4~5 dots		≤ 2
			Consecutive 6 dots		0
		$1/3 \leq S < 2/3$		Dot defect +0.5	
$2/3 \leq S$		Dot defect +1			
15	Lints, black/white line	$W \leq 0.03$		-----	Ignore
		$0.03 < W \leq 0.05$	$L \leq 6$		Ignore
			$6 < L \leq 12$	≤ 3	
		$0.05 < W \leq 0.1$	$12 < L$		0
			$L \leq 0.6$	Ignore	
			$0.6 < L \leq 5$	≤ 2	
$0.1 < W$		$(W+L)/2=D$		Conform to No.13	

D:Average diameter [mm], W:Width [mm], L:Length [mm], S=(bright spot size)/(dot size)

DOCUMENT CONTROL SECTION

DATE

						LQ150X1DWF1 (FLC38XGC6V-06P)	
						LD17421	
						CUST.	
EDIT	DATE	DESIG.	CHECK	APPR.	DESCRIPTION		SHARP CORPORATION
		CHECK		APPR.		20 /	

A

B

D

E

F

13. ENVIRONMENTAL SPECIFICATIONS

Table 13-1 shows the environmental specifications.

Table 13-1. Environmental Specifications

Item	Condition		Remark
Temperature	Operation	0~50°C	Temperature on surface of LCD panel (display area.)
	Storage	-20~60°C	
Humidity	Operation	20~85%RH	Maximum wet-bulb temperature should not exceed 29°C. No condensation.
	Storage	5~85%RH	
Vibration	Non-operation	10~500Hz, 1 cycle/20minute, 2G, 1.5mm max, 2hour each X, Y and Z directions	For single module without package.
Shock	Non-operation	50G, 6ms, 1time each ±X, ±Y and ±Z directions.	

NOTE: Table 13-2 and Fig. 13-1 show the shock resistance standard when module is packaged.

Table 13-2. Shock Resistance Standard when Module is Packaged

Dropping location	Dropping height	Count
A ~ J	60cm	1 time

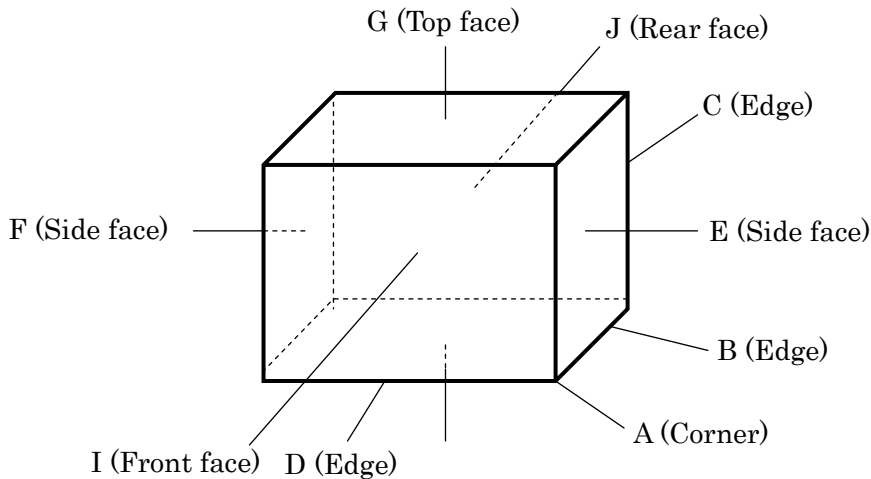

Fig.13-1. Direction to apply shock to package

DOCUMENT CONTROL SECTION

DATE

						LQ150X1DWF1 (FLC38XGC6V-06P)		
						LD17421		CUST.
EDIT	DATE	DESIG.	CHECK	APPR.	DESCRIPTION		SHARP CORPORATION	21 /
DESIG.			CHECK		APPR.			

14. INDICATIONS

This module has the following indications.

Product label

- (1) SHARP Model number : LQ150X1DWF1
- (2) Model number : FLC38XGC6V-06P
- (3) Version number : 02A (Example)
 - 1st 2 digits "01" means operational version.
 - 3rd alphabet means functional version.
- (4) Company name : SHARP
- (5) Manufacturing number : 4 6 XXX 0 0 0 0 1
 - Serial number (To be reset every month on 1st.)
 - Manufacturing code (For internal use)
 - Manufacturing month (Oct. = X, Nov. =Y, Dec. =Z)
 - Last digit of manufacturing year.
- (6) Country of origin : MADE IN JAPAN
- (7) Disposal method of cold-cathode tubes. (See Fig.14-1)
- (8) Caution when changing cold-cathode tubes. (See Fig. 14-2)

•FLUOREACENT LAMPS IN THIS PRODUCT CONTAIN MERCURY AND MUST BE DISPOSED OF ACCORDING TO LOCAL ORDINANCE, STATE OR FEDERAL LAWS.
 •この製品の内部の蛍光管には水銀が含まれていますので、地方自治体の条例、州法または連邦法に従って廃棄してください。

Fig.14-1

•WHEN CHANGING COLD CATHODE FLUORESCENT LAMPS, FOLLOW OPERATING SPECIFICATIONS. ESPECIALLY BE CAREFUL ABOUT THE LAMPS SIDE-EDGE
 •蛍光管の交換は作業仕様書に従って行って下さい。特に蛍光管ホルダ側面のエッジに気をつけて下さい。

Fig.14-2

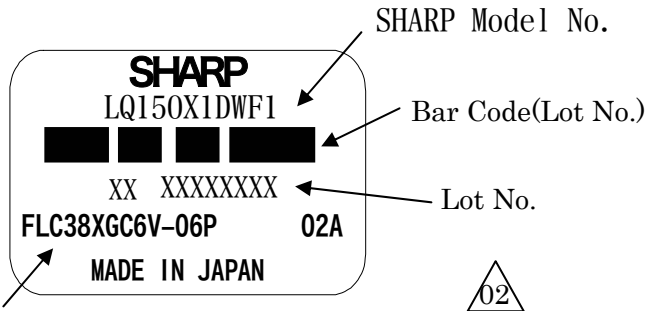

Fig.14-3 Product label (example)

DOCUMENT CONTROL SECTION

DATE

						LQ150X1DWF1 (FLC38XGC6V-06P)		
						LD17421		CUST.
02	20050420				Change product label			
EDIT	DATE	DESIG.	CHECK	APPR.	DESCRIPTION			SHARP CORPORATION

15. PACKAGING

Separately specified in packaging specifications.

15-1. Packaging specifications

- (1) 5 LCD modules / 1 package.
- (2) Weight: approximately 10kg / 1 package.
- (3) Outline dimensions : 353mm (W)×268mm (D) ×462mm (H)

15-2. Packaging method

Fig.15-2 (a),(b),(c),(d) show the packing method.

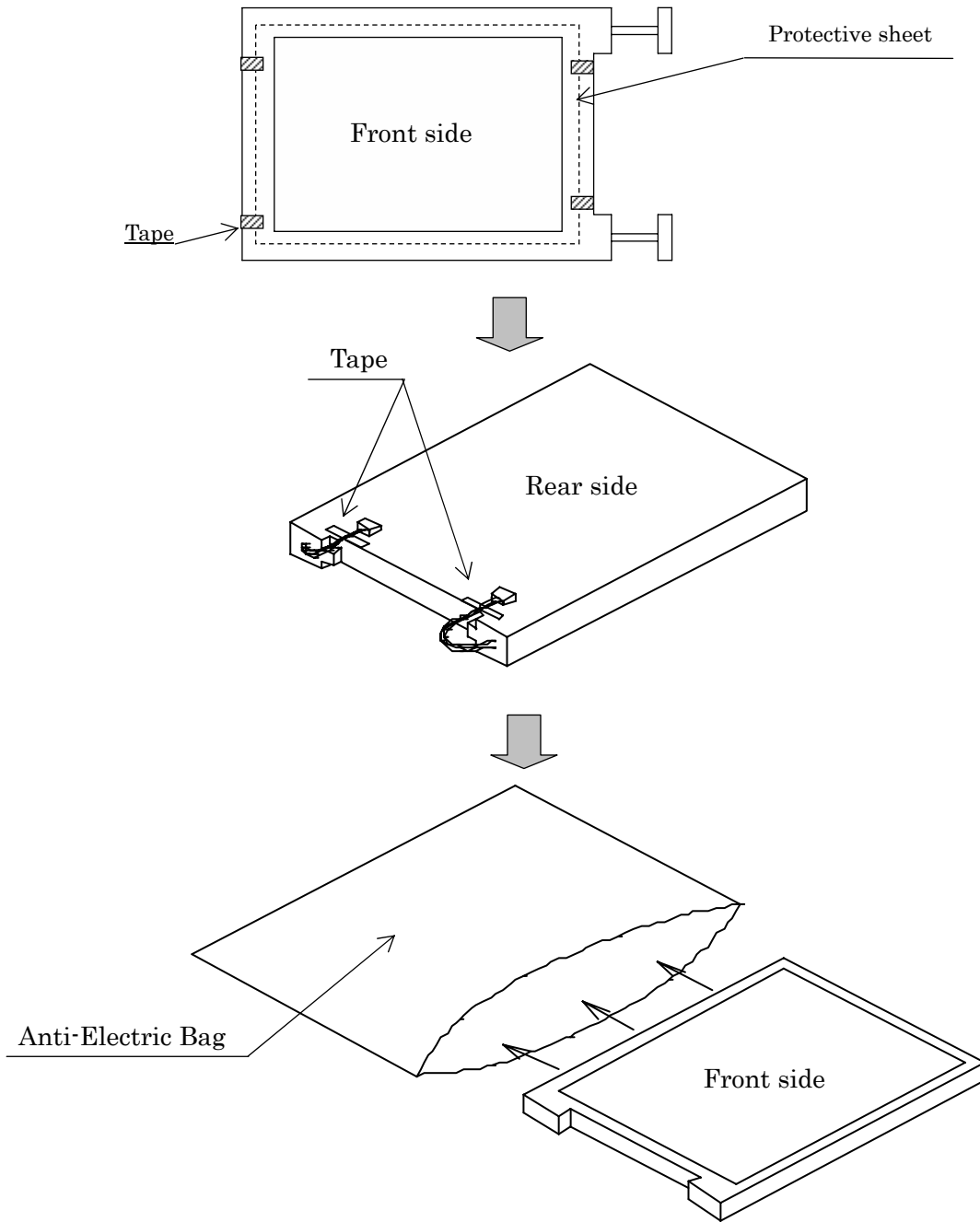
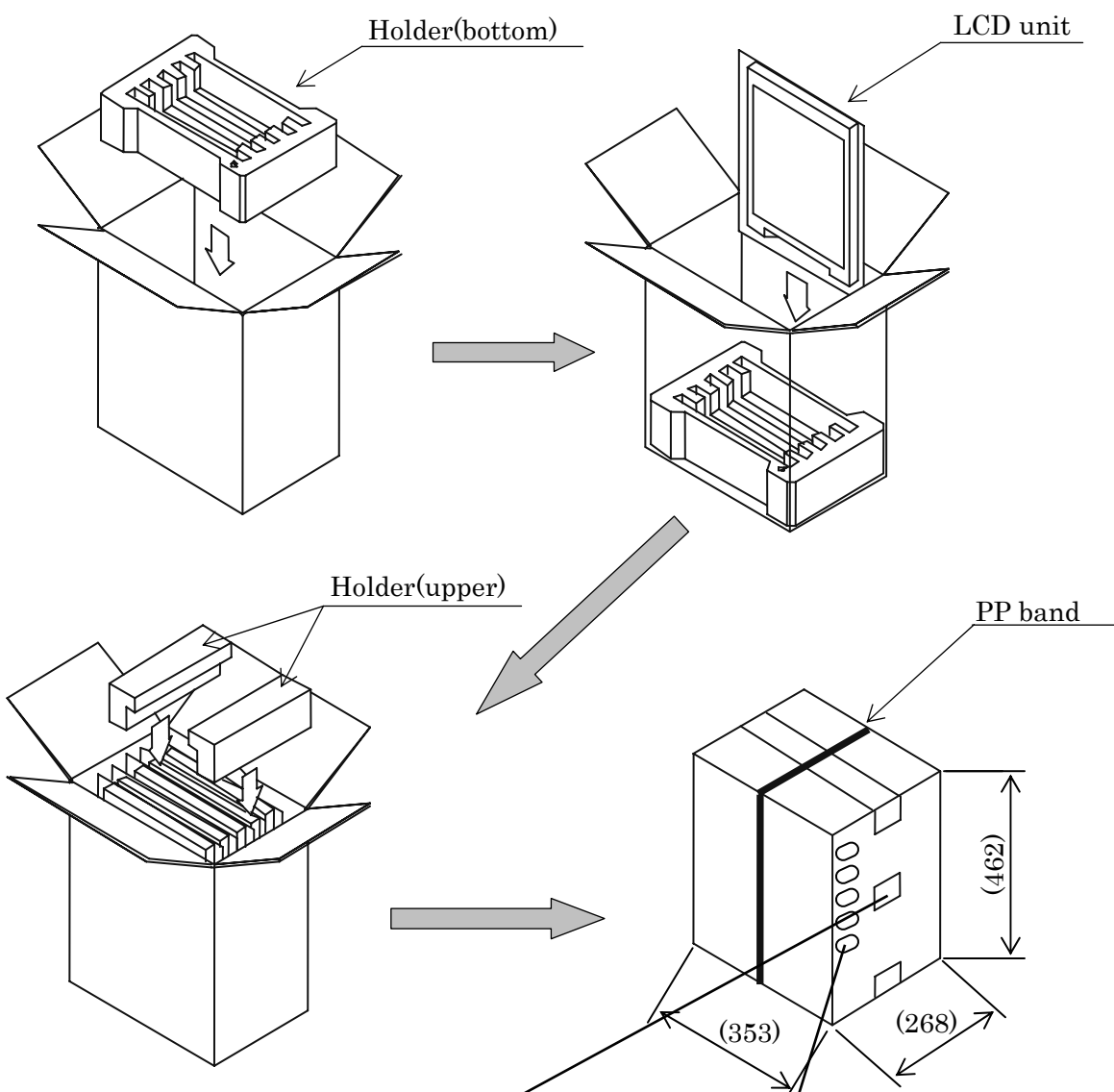

Fig.15-2(a) Packaging Method

DOCUMENT CONTROL SECTION
DATE

						LQ150X1DWF1 (FLC38XGC6V-06P)		
						LD17421		CUST.
02 20050420						Add tape.		
EDIT	DATE	DESIG.	CHECK	APPR.	DESCRIPTION		SHARP CORPORATION	23 /
DESIG.			CHECK		APPR.			



Carton Label 1 (example)

社内品番: (4 S) LQ150X1DWF1

Bar code (①)

LotNO. : (1 T) 2005, X, XX

Bar code (②)

Quantity: (Q) 5 pcs

Bar code (③)

ユーザ品番 : []

シャープ物流用ラベルです。 [④]

Carton Label 2 (example) : 5 pcs

SHARP

LQ150X1DWF1

■■■■

XX XXXXXXXX

FLC38XGC6V-06P 02A

MADE IN JAPAN

Label format is same as product label .
The number of label attachment depends on module quantity.

Fig.15-2(b) Packaging Method

DOCUMENT CONTROL SECTION

DATE

						LQ150X1DWF1 (FLC38XGC6V-06P)		
						LD17421		CUST.
04 20050420						Change carton label format.		
EDIT	DATE	DESIG.	CHECK	APPR.	DESCRIPTION		SHARP CORPORATION	
DESIG.			CHECK		APPR.			

1

2

3

4

A

B

D

E

F

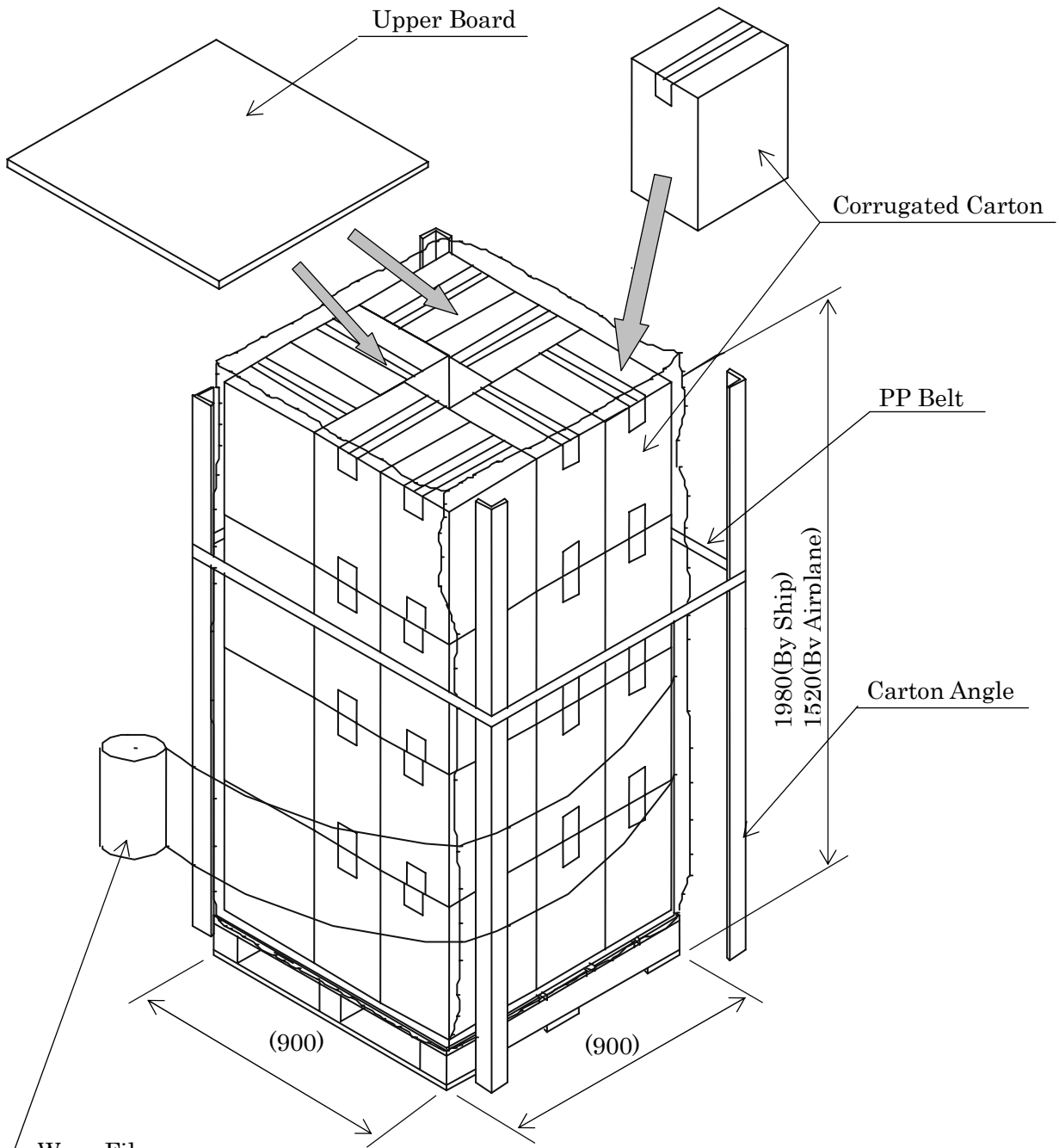

Wrap Film

Up and Down : 3 times wrap
Middle : 2 times wrap

Note:1) 8 boxes×4 layers (maximum 32 boxes) : by ship
8 boxes×3 layers (maximum 24 boxes) : by airplane
Note:2) This drawing shows marine transportation specification.

Fig.15-2(c) Packaging Method

DOCUMENT CONTROL SECTION

DATE

EDIT	DATE	DESIG.	CHECK	APPR.	DESCRIPTION
DESIG.			CHECK		APPR.

LQ150X1DWF1
(FLC38XGC6V-06P)

LD17421

CUST.

SHARP CORPORATION

25 /

1

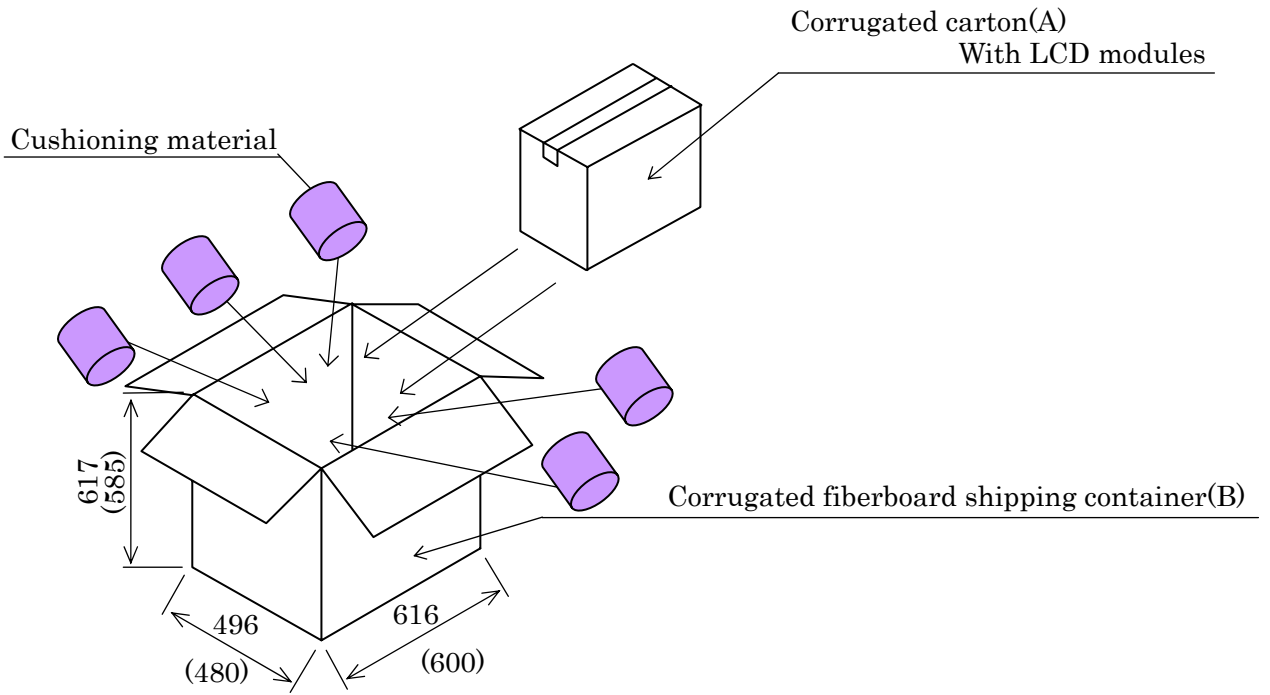

Note 1) The carton (A) should be placed in the middle of the container(B) with enough cushioning materials.

Note 2) The figures in () show inside measurements of the container(B).

Figure.15-2(d) Packaging Method

DOCUMENT CONTROL SECTION

DATE

						LQ150X1DWF1 (FLC38XGC6V-06P)		
						LD17421		CUST.
EDIT	DATE	DESIG.	CHECK	APPR.	DESCRIPTION		SHARP CORPORATION	26 /
DESIG.			CHECK		APPR.			

1

16. WARRANTY

The warranty period is one year after manufacturing. Products which fail during this period are repaired or replaced without charge, unless the failure is caused by user.

17. PRECAUTIONS

Adhere to the following precautions to properly use this LCD module.

(1) Fail safe design

LCD module has an inherent chance of failure. Customers must protect against injury, damage or loss from such failures by incorporating safety design measures into your facility and equipment such as redundancy, fire protection, and prevention of over-current levels and other abnormal operating conditions.

(2) Handling of LCD panel

① Do not apply any strong mechanical shock to the LCD panel.

Since the LCD panel is made of glass, excessive shock may damage the panel or cause a malfunction.

② Do not press hard on the LCD panel surface.

In the LCD panel, the gap between two glass plates is kept perfectly even to maintain display properties and reliability. The hard pressure on the LCD panel may cause the following problems. If the pressure is over 2kg/cm2, the problem don't return to normal Condition.

- ① Ununiformity of color
- ② Disorder of orientation of liquid crystal

Problem ① returns to normal condition after a while. Problem ② returns to normal condition by turning the power off and turning on again.

However these operations should be avoided to insure reliability.

③ Do not scratch the polarizer film on the LCD panel surface.

- Do not press or rub the display surface with a hard tool, pincet, etc.
- For handling, use cotton or conductive gloves so that the display surface is not stained.
- For If the display surface is stained by dust or dirt, clean it as follows with a soft cloth (deer skin, etc.)

[Dust] Wipe off with a soft cloth. (do not rub.)

[Dirt] Wipe off lightly with a soft cloth after soaking in the clear water and squeezing hard out of water drops. Only if the dirt is hardly wiped off, use isopropyl alcohol or ethanol.

Be careful not to splash the water or the solvent and water penetrated between the polarizer and the LCD panel.

Do not use solvents such as ketone (acetone, etc.) and aromatics (xylene, toluene, etc.)

- If saliva or water drops are left for long time, it may deform partial deformation or discolored. Wipe off immediately in the same way as for dirt.
- Do not allow oil to adhere to the module, since the cleaning of oil is difficult.

④ Do not place or contact objects on the display surface for a long period of time.

That's because this may make some parts of the LCD module distorted and the display quality may decline.

DOCUMENT CONTROL SECTION

DATE

						LQ150X1DWF1 (FLC38XGC6V-06P)		
						LD17421		CUST.
EDIT	DATE	DESIG.	CHECK	APPR.	DESCRIPTION	SHARP CORPORATION		PAGES
DESIG.			CHECK		APPR.			27 /

(3) Handling of LCD module

① Do not pull the cold-cathode tube cable strongly.

If the cable is pulled with the load of 2kg or more, the cable may be damaged or reliability may decrease.

② Assemble the module into user's system in a dust free environment.

If conductive foreign matter adheres to the module, failures may occur.

③ Take anti-static measures for assembling the module.

Since the LCD module contains CMOS-ICs, the following considerations are necessary.

- For assembling the module, operator should be grounded and wear cotton or conductive gloves.
- Floor of work area and work table to assemble the LCD module should be covered with electrostatic shielding in order to discharge static electricity via an earth wire.
- If necessary, ground operation tools (soldering iron, radio pliers, pincet, etc.).
- Do not take the module out of the conductive bag until the time when the module is assembled.
- Assemble the module under low humidity (50%RH or less).

④ Do not pull the connecting cable on the rear face of the LCD module strongly.

⑤ Do not disassemble or remodel the LCD module.

If this LCD module is disassembled or remodeled, it may have some trouble, or the display quality and reliability may not be assured.

(4) Precautions for operating the LCD module

① Adhere to the specified power supply sequence.

If not followed, the CMOS-IC may cause a latch-up, or the DC voltage may be applied the liquid crystal, and a failure or serious deterioration in display quality may occur.

② Do not operate the LCD module when condensation is present.

If the LCD module is operated when condensation is on the terminals of the LCD panel, the terminals cause electrochemical reaction, and may reach disconnection. Condensation easily occurs especially when the module is moved from a cold environment to a warm environment.

③ Trouble that occurs when the LCD module is used at not recommended temperature.

- Operation at high temperature(>50°C) :Display colors shift to blue.
- Storage at high temperature(>60°C) :The polarizer film deteriorates and contrast decreases.
- Operation at low temperature(<0°C) :The response speed decreases considerably.
- Storage at low temperature (<-20°C) :The liquid crystal may solidify and become damaged.

④ Always input the control signals at the correct timing.

If control signals (DCLK, or ENAB) are not input, or if the timing is out of the specified timing, DC voltage may be applied to the liquid crystal and, as a result, cause image sticking or deterioration of contrast.

DOCUMENT CONTROL SECTION
DATE

						LQ150X1DWF1 (FLC38XGC6V-06P)		
						LD17421		CUST.
EDIT	DATE	DESIG.	CHECK	APPR.	DESCRIPTION		SHARP CORPORATION	28 /
DESIG.			CHECK			APPR.		

(5) Precautions on designing module mounting

① Do not press the display surface and bottom face of the LCD module.

Display quality or reliability may be deteriorated if the installation of the LCD module is inappropriate and, as a result, excessive pressure is applied to the surface of LCD screen.

Brightness uniformity or the reliability of CCFL may decrease if the pressure is applied to the backlight module.

② Consider the module mounting design, so that twisting and bending do not occur to the LCD module.

Excessive twisting and bending may damage display quality and reliability.

③ The power cable length between the LCD module and inverter should not be extended.

Otherwise the backlight may not light or flickering may occur.

④ Do not make the power cable of the backlight clung to a metal plate, etc.

Backlight frequency current for backlight driving may leak to the metal and desired brightness may not be assured.

⑤ When Mounting LCD module with M4 screw (x4) should be screw up under 5.75kgf torque.

(6) Storage method

① Do not store the LCD module in an atmosphere of organic solvent or corrosive gas.

In an organic solvent atmosphere, the polarizer film discolors and display quality deteriorates.

In a corrosive gas environment, various problems may occur.

② Store the LCD module in a SHARP package.

At storing, SHARP packages can be stacked up to 4 boxes.

The LCD module is in an anti-static bag. Keep the module in that status.

③ It is recommended that the storage environment should be humidity controlled, cool and dark.

Recommended storage environment

- Place : Dark (avoid direct sunlight)
- Temperature : 10~35°C
- Humidity : 50~60%RH

Note) If the module is left in an environment of 60°C or more for a long period of time, optical characteristics may deteriorate.

(7) Disposal Method

① LCD module

The components of this LCD module can be grouped into metal, resin, glass and so on. As the backlight contains CCFL which includes mercury, it must be disposed according to the local ordinance or regulations.

② Package

All the packages are made of recyclable papers except the anti-ESD bag.

DOCUMENT CONTROL SECTION

DATE

						LQ150X1DWF1 (FLC38XGC6V-06P)		
						LD17421		CUST.
EDIT	DATE	DESIG.	CHECK	APPR.	DESCRIPTION	SHARP CORPORATION		29 /
DESIG.			CHECK		APPR.			

(8) CAUTION IN DESIGNING INVERTER

Fluorescent lamps driven by high voltage are included in this LCD module. Please stand to the instructions below when designing inverter that lights the fluorescent lamps. Otherwise it may lead to FATAL FAILURE, such as SMOKING or FIRING.

- ① **APPLY PROTECTIVE CIRCUIT** in preparation for lamp breaking, wire breaking and short circuit. The protective circuit should also detect half open circuit and wire breaking in narrow gap etc.. Otherwise it may lead to fatal failure.
- ② **KEEP ENOUGH CURRENT CAPACITY** of inverter output for leakage current, which leaks from lamps and wire to surrounding metal material. Usually output current of about 1.5 times as same as the lamp current is necessary. But it sometimes varies due to characteristics of the inverter itself. So before determining design, please check characteristics of the inverter by connecting it to the LCD module.
- ③ **KEEP ENOUGH TEMPERATURE MARGIN** for each parts mounted on inverter. Temperature of the parts becomes higher when they are mounted in the final products due to heating inside. The temperature of each parts **MUST NOT** increase over the guaranteed temperature.

A

B

D

D

DOCUMENT CONTROL SECTION

DATE

E

F

LQ150X1DWF1
(FLC38XGC6V-06P)

LD17421

CUST.

EDIT	DATE	DESIG.	CHECK	APPR.	DESCRIPTION	TOTAL
						30 /

SHARP CORPORATION

30 /

(9) Return method of the LCD module requested for repair or analysis of the problem

- When returning the LCD modules, adhere to the following procedures not to damage the LCD panel or the backlight cables. (Fig. 17-1(a)~(b))

When the LCD module is returned without following the specified packaging procedures, SHARP will not take responsibility for the damages caused by the failure of the packaging method.

① Attach protective sheet.

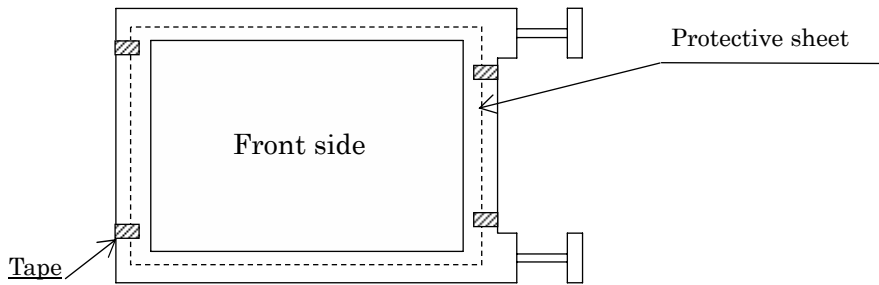

② Hook the backlight cables.

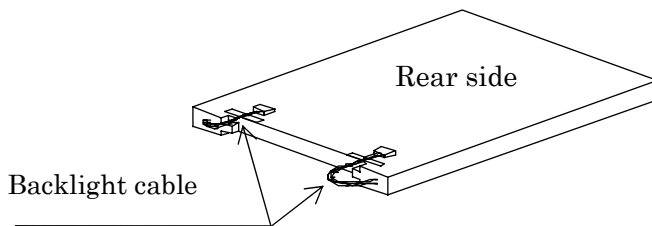

* If the cables are not fixed, the connectors may scratch the LCD panel surface or the cables may be damaged.

③ Put the LCD module into the anti-electrostatic bag
(Please do not use torn anti-electrostatic bags)

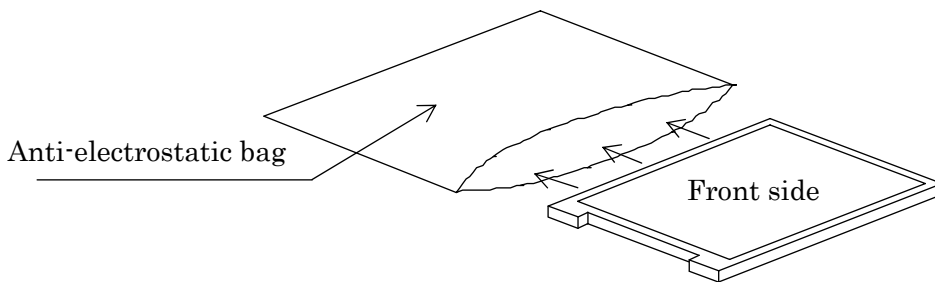

Fig. 17-1(a) Packaging method

DOCUMENT CONTROL SECTION
DATE

						LQ150X1DWF1 (FLC38XGC6V-06P)	
						LD17421	CUST.
02	20050420				Add tape.		
EDIT	DATE	DESIG.	CHECK	APPR.	DESCRIPTION	SHARP CORPORATION	
DESIG.			CHECK		APPR.		

④ Storage into the carton box

- When using the carton box manufactured by SHARP
(Please use carton boxes and arrowheads that are not collapsed)

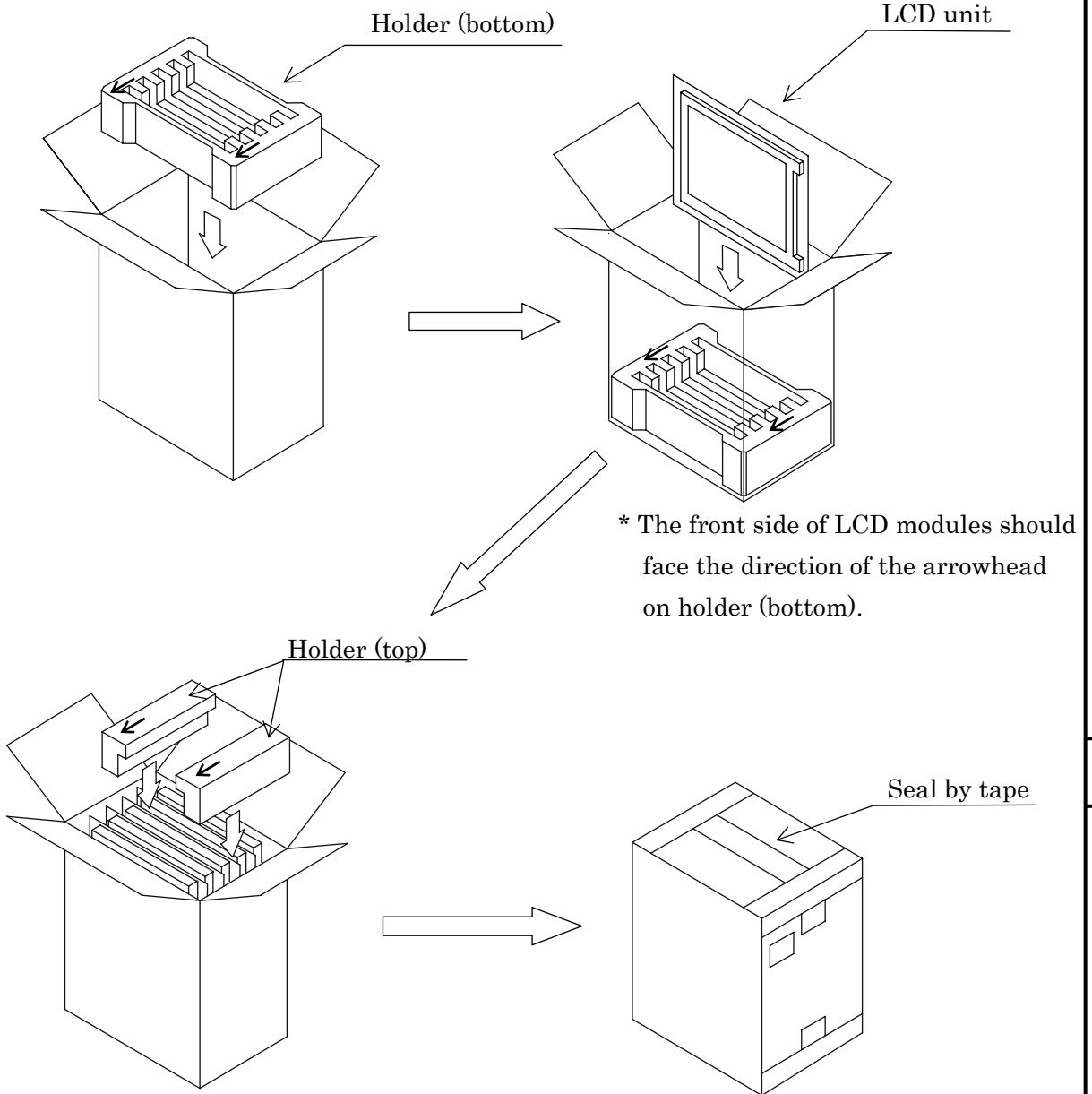

* The direction of the arrowhead on holder (top) should face the front side of the LCD modules.

The arrowheads are shown on the holders.

Fig. 17-1(b) Packaging method

- When not using the carton box manufactured by SHARP
Please pack the LCD modules one by one and make sure not to damage the LCD modules when transporting.

DOCUMENT CONTROL SECTION

DATE

						LQ150X1DWF1 (FLC38XGC6V-06P)		
						LD17421		CUST.
EDIT	DATE	DESIG.	CHECK	APPR.	DESCRIPTION	SHARP CORPORATION		32 /
DESIG.			CHECK		APPR.			

(10) Others

① If the LCD panel is damaged, do not inhale and do not swallow the liquid crystal.

If the liquid crystal adhere to the body or cloths, wash it off with soap immediately.
Follow regular precautions for electronic components.

② Flux residue on the printed circuit board is harmless to the quality and reliability of LCD module.

SHARP has adopted non-wash technology on module assembly process.

A

B

E

F

18. PRECAUTIONS FOR USE

This Product is designed, developed and manufactured as contemplated for general use, including without limitation, general office use, personal use, household use, and ordinary industrial use, but is not designed, developed and manufactured as contemplated for use accompanying fatal risks or dangers that, unless extremely high safety is secured, could lead directly to death, personal injury, severe physical damage or other loss (hereinafter "High Safety Required Use"), including without limitation, nuclear reaction control in nuclear facility, aircraft flight control, air traffic control, mass transport control, medical life support system, missile launch control in weapon system. If customer's product possibly falls under the category of High Safety Required Use, please consult with our sales representatives in charge before such use. In addition, SHARP shall not be liable against the Customer and/or any third party for any claims or damages arising in connection with the High Safety Required Use of the Product without permission.

19. MISCELLANEOUS

Specifications of the TFT-LCD panel and other components used in the LCD module are subject to change. Both parties shall discuss together before change.

If any doubt is raised in the content of the specifications, both parties shall discuss and make best effort for the agreement.

D

D

DATE	DOCUMENT CONTROL SECTION

						LQ150X1DWF1 (FLC38XGC6V-06P)		
						LD17421		CUST.
EDIT	DATE	DESIG.	CHECK	APPR.	DESCRIPTION	SHARP CORPORATION		33 /
DESIG.			CHECK		APPR.			

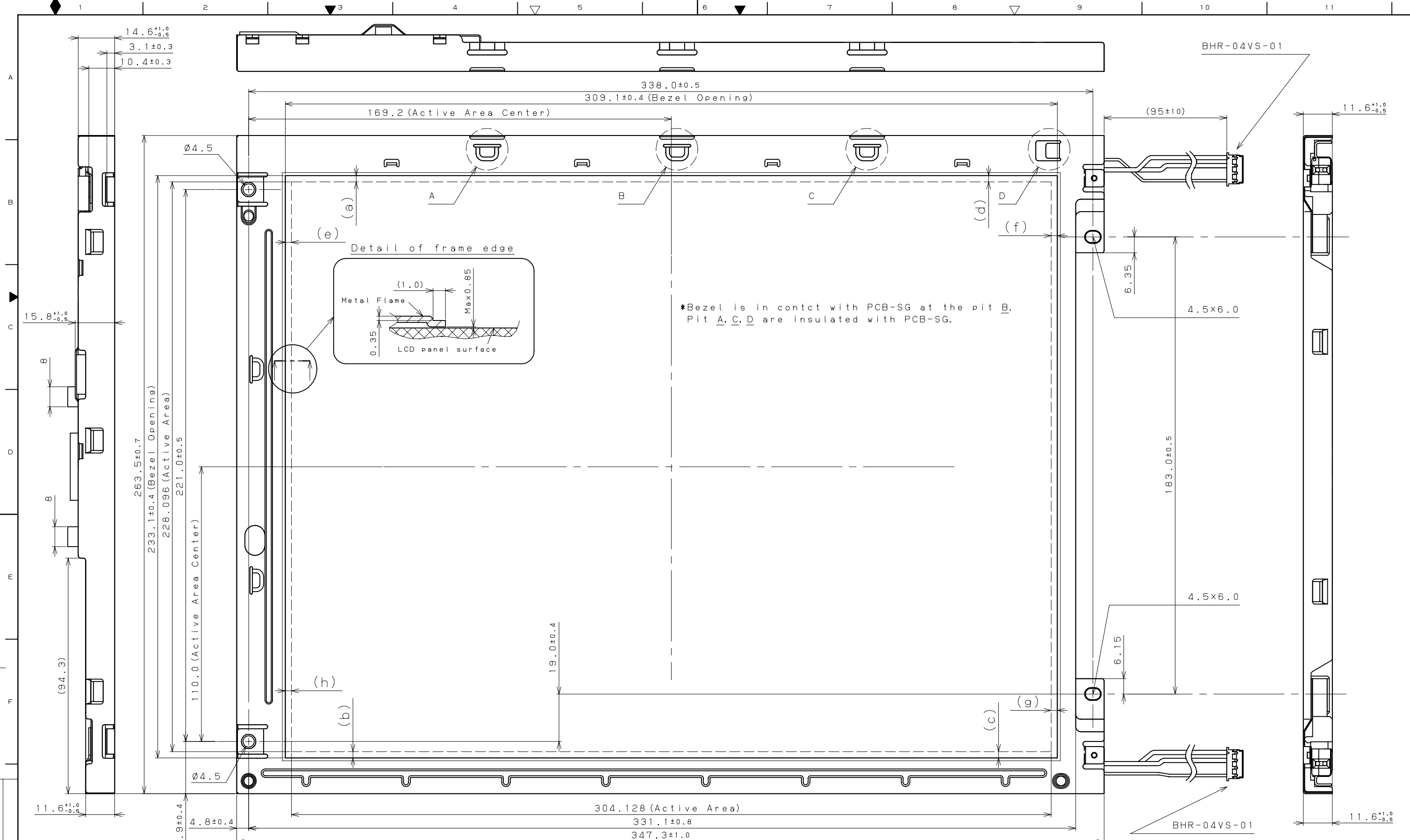

Front View

DATE DOCUMENT CONTROL SECTION

		Commercial Tolerance					
Item	Dimension	0.5	1.20	3.15	10.00	20.00	
		30	or less	or less	or less	or less	
Center distance (metal)	±0.1	±0.1	±0.2	±0.3	±0.5	FN111-10	Class ()
Center distance (resin)	±0.1	±0.2	±0.4	±0.5	±0.7	FN111-11	Metallic sinter, Aluminum alloy casting, Metal mold, Sand mold, Glass processing, Iron casting, Copper alloy casting, Rubber formlina, Rubber processing, Sponse formlina, Sponse processing
General dimensions (metal)	±0.2	±0.3	±0.5	±0.8	±1.2	FN111-13	Plastic mold FN111-14 Die cast
General dimensions (resin)	±0.2	±0.3	±0.5	±0.8	±1.2		
Assembly dimensions	±0.2	±0.3	±0.5	±0.8	±1.2		
Bend dimensions (longitudinally 315 or less)	±0.2	±0.3	±0.5	±0.8	±1.2		

MATER.		FINISH		TITLE LQ150X1DWF1 (FLC38XGC6V-06P)		SCALE :	
DESIG.		CHECK		DRAW. NO. LD17421		CUST.	
EDT.		DATE		DESIG.		CHECK	
DESCRIPTION		APPR.		SHARP CORPORATION		31/	

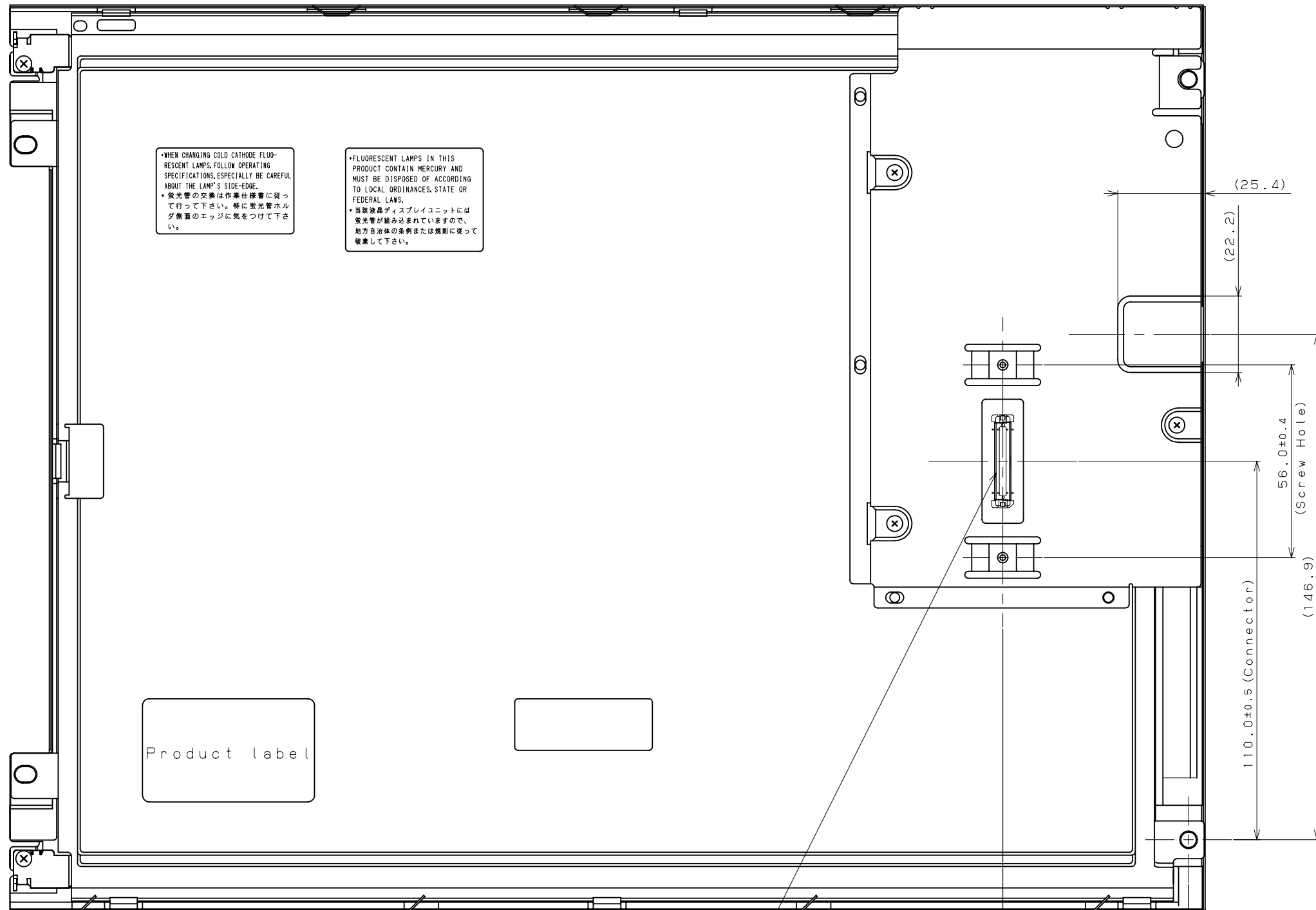

•WHEN CHANGING COLD CATHODE FLUORESCENT LAMPS, FOLLOW OPERATING SPECIFICATIONS, ESPECIALLY BE CAREFUL ABOUT THE LAMP'S SIDE-EDGE.
 •蛍光灯の交換は作業仕様書に従って行って下さい。特に蛍光灯ホルダ側面のエッジに気をつけて下さい。

•FLUORESCENT LAMPS IN THIS PRODUCT CONTAIN MERCURY AND MUST BE DISPOSED OF ACCORDING TO LOCAL ORDINANCES, STATE OR FEDERAL LAWS.
 •当該液晶ディスプレイユニットには蛍光灯が組み込まれていますので、地方自治体の条例または規則に従って破棄して下さい。

Product label

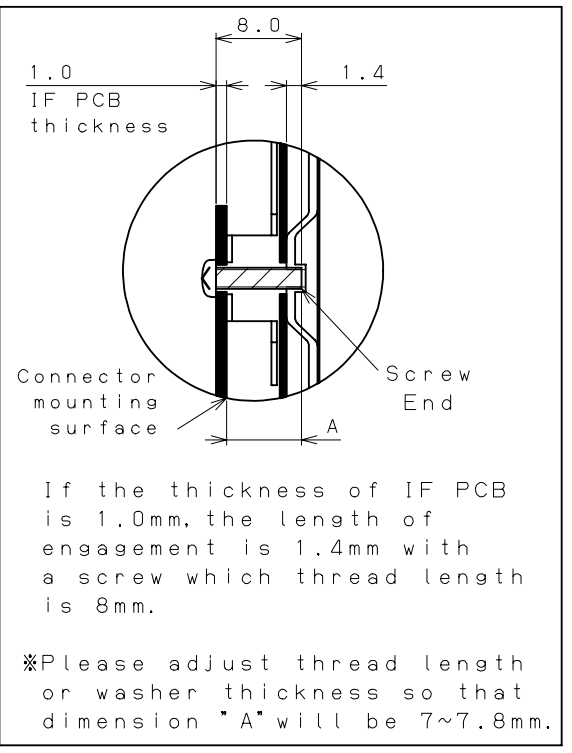
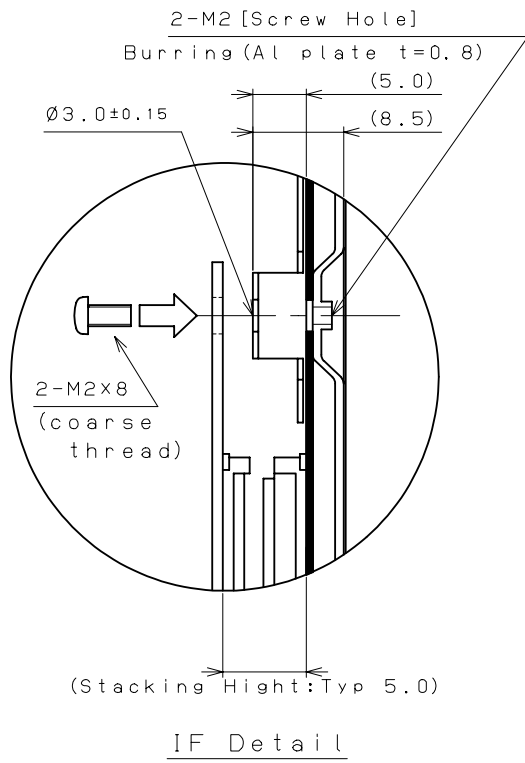

52760-0600 (MOLEX)

54.0±0.4 (Connector)
 54.0±0.4 (Screw Hole)

Rear View

DATE DOCUMENT CONTROL SECTION

		Commercial Tolerance							
		0.5	1.20	3.15	10.00	20.00	FN111-10 Class ()		
		30 or less	or less	or less	or less	or less			
FN111-12	Machining, Sheet metal working	Item	Dimension	0.1	±0.1	±0.2	±0.3	±0.5	Metallic sinter, Aluminum alloy casting (Metal mold, Sand mold), Glass processing, Iron casting, Copper alloy casting, Rubber forming, Rubber processing, Sponge forming, Sponge processing
		Center distance (metal)		±0.1	±0.1	±0.2	±0.3	±0.5	
		Center distance (resin)		±0.1	±0.2	±0.4	±0.5	±0.7	
		General dimensions (metal)		±0.1	±0.2	±0.4	±0.5	±0.7	
		General dimensions (resin)		±0.1	±0.2	±0.4	±0.5	±0.7	
Assembly dimensions		±0.2	±0.3	±0.5	±0.8	±1.2	FN111-13 Plastic mold FN111-14 Die cast		
Bend dimensions (longitudinally 315 or less)		±0.2	±0.3	±0.5	±0.8	±1.2			
MATER.		FINISH					TITLE LQ150X1DWF1 (FLC38XGCV-06P) SCALE :		
							DRAW. NO. LD17421 CUST.		
EDIT.	DATE	DESIG.	CHECK	DESCRIPTION		SHARP CORPORATION 35/35			
DESIG.			CHECK	APPR.					