

LQ190E1LW01

TFT-LCD Module

Spec. Issue Date: May 11, 2005

No: LD17443

PREPARED BY : DATE	<h1>SHARP</h1> <p>Mobile Liquid Crystal Display GROUP SHARP CORPORATION</p> <h2>SPECIFICATION</h2>	SPEC No. LD17443
APPROVED BY : DATE		FILE No.
		ISSUE : May.11.2005
		PAGE : 38 pages
		APPLICABLE GROUP Mobile Liquid Crystal Display Group

DEVICE SPECIFICATION

TFT-LCD Module

MODEL No.

LQ190E1LW01

(FLC48SXC8V-11AA)

These parts have corresponded with the RoHS directive.

CUSTOMER : _____

CUSTOMER'S APPROVAL

DATE _____

BY _____

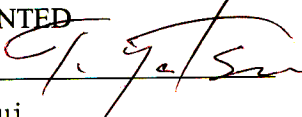
PRESENTED
 BY 
 T. Yatsui
 Department general manager
 Product Quality Assurance DEPT. III
 Mobile Liquid Crystal Display Group
 SHARP Corporation

BY 
 T. Naka
 Division deputy general manager of
 Mobile LCD Design Center III
 Engineering Department II
 Mobile LCD Design Center III
 Mobile Liquid Crystal Display Group
 SHARP Corporation

REVISION HISTORY

A

A

Revision	Date	Prepared	Checked		Approved	Summary
01A	Apr. 9,2004	K. Yonemura	T. Ito		F. Yamada	1 st issue. Change manufacture to SHARP.
02A	Jan. 27,2005	K. Yonemura	E. Nitto	T. Ito	F. Yamada	RoHS standard conformed product. Change manufacture to SHARP.

B

B

C

C

D

D

DOCUMENT CONTROL SECTION

DATE

E

F

05	20040802	K. Yonemura		T. Ito	Revised P8,10	TITLE	LQ190E1LW01	
04	20040708	K. Yonemura		T. Ito	Revised P8	DRAW. NO.	(FLC48SXC8V-11AA)	
07	20050420	S. Fukutoku		T. Ito	Revised P3,19,23,26,31,33-36		LD17443	CUST.
06	20050126	K. Yonemura	E. Nitto	T. Ito	Add. of Rev.02A			
EDIT	DATE	DESIG.	CHECK	APPR.	DESCRIPTION	SHARP CORPORATION		
	DESIG.	20040409	K. Yonemura	CHECK		APPR.	T. Ito	1/38

TABLE OF CONTENTS

1.	APPLICATIONS	3
2.	PRODUCT NAME AND MODEL NUMBER	3
2-1.	Product Name	3
2-2.	Model Number	3
3.	OVERVIEW	3
4.	CONFIGURATION	3
5.	MECHANICAL SPECIFICATIONS	4
6.	ABSOLUTE MAXIMUM RATING	5
7.	RECOMMENDED OPERATING CONDITIONS	5
8.	ELECTRICAL SPECIFICATIONS	6
9.	OPTICAL SPECIFICATIONS	8
10.	INTERFACE SPECIFICATIONS	12
10-1.	Signal Descriptions	12
10-2.	LVDS Data Assignment	13
10-3.	Color Data Assignment	15
10-4.	Input Signal Timing	16
10-5.	Correspondence between Data and Display Position	18
10-6.	Power Supply Sequence	18
11.	BACK-LIGHT SPECIFICATIONS	19
11-1.	Pin configuration for Back-light	19
11-2.	Life	19
11-3.	Lamp assembly set	19
12.	APPEARANCE SPECIFICATIONS	20
12-1.	Appearance	20
12-2.	Dot defects	21
13.	ENVIRONMENTAL SPECIFICATIONS	22
14.	INDICATIONS	23
15.	PACKAGING	23
15-1.	Packing Specifications	23
15-2.	Packing Method	23
16.	WARRANTY	29
17.	PRECAUTIONS	29
18.	PRECAUTIONS FOR USE	36
19.	MISCELLANEOUS	36

A

A

B

B

C

C

D

D

E

DOCUMENT CONTROL SECTION

DATE

F

TITLE	LQ190E1LW01
	(FLC48SXC8V-11AA)
DRAW. NO.	LD17443
CUST.	

EDIT	DATE	DESIG.	CHECK	APPR.	DESCRIPTION	SHARP CORPORATION	2/
DESIG.			CHECK		APPR.		

1. APPLICATION

This specification is applied to the 19-inch SXGA supported TFT-LCD module.

A

A

2. PRODUCT NAME AND MODEL NUMBER

2-1 Product Name : **LCD Module**

2-2 Model Name : LQ190E1LW01
(FLC48SXC8V-11AA)

B

B

3. OVERVIEW

This LCD module has a TFT active matrix type liquid crystal panel 1280x1024 pixels, and diagonal size of 48cm(19-inch). This LCD has a LVDS dual interface and can display 16,777,216 colors.

The power supply of this LCD module is +5V DC voltage.

C

C

4. CONFIGURATION

This LCD module consists of a color TFT-LCD panel that is mounted with TFT driver ICs and a cold-cathode fluorescent tube back-light.

The inverter for the back-light is not included.

Figure 4-1 shows a block diagram of this LCD module.

D

D

DOCUMENT CONTROL SECTION

DATE

E

F

						TITLE	LQ190E1LW01 (FLC48SXC8V-11AA)	
						DRAW. NO.	LD17443	CUST.
07	20050420					The model name was changed.		
EDIT	DATE	DESIG.	CHECK	APPR.	DESCRIPTION			
					SHARP CORPORATION			
DESIG.			CHECK					3/

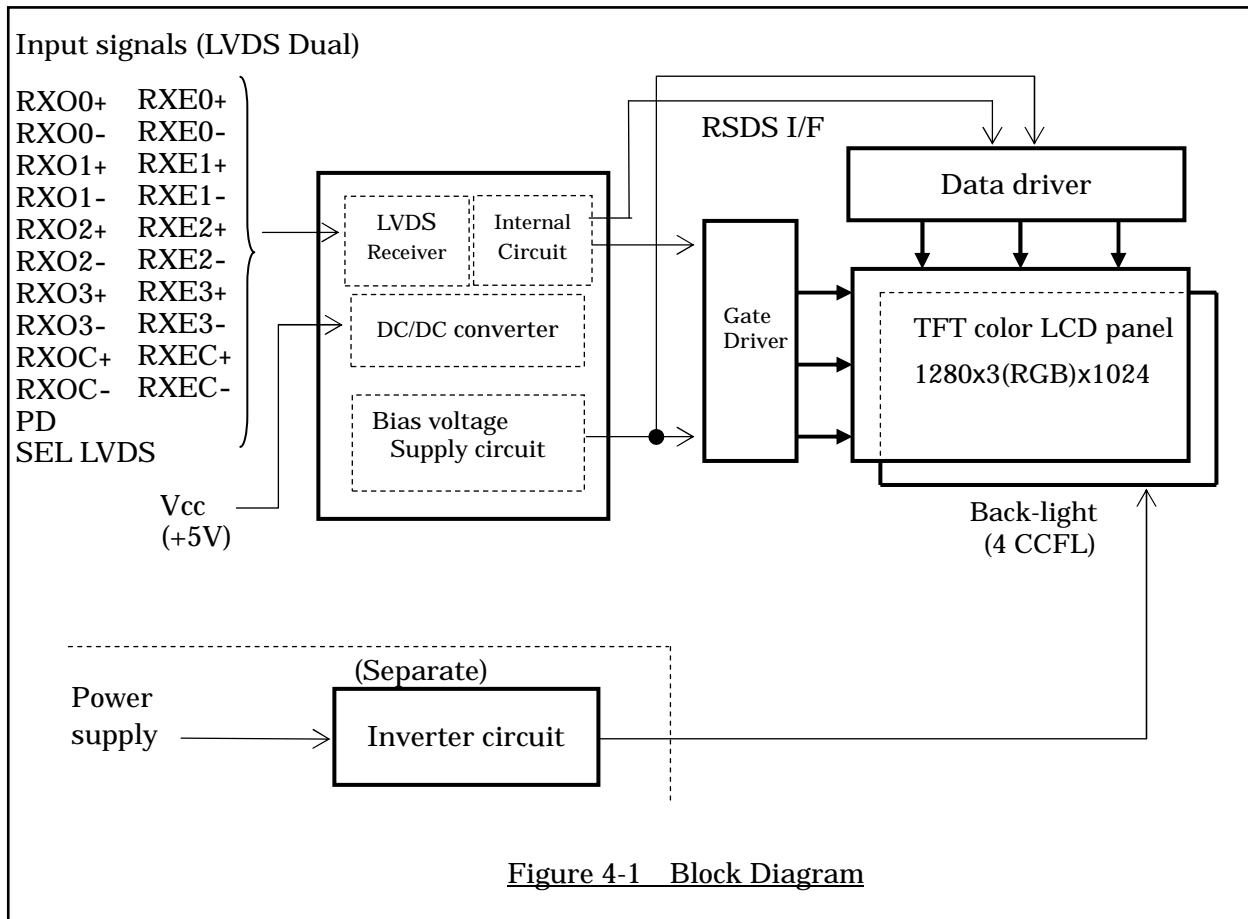

Figure 4-1 Block Diagram

5. MECHANICAL SPECIFICATIONS

Table 5-1 shows the mechanical specifications of this LCD module.

Table 5-1 Mechanical Specifications

Item	Specifications	Unit	Remark
Dimensions	404.2x3330x20(TYP.)	mm	Edge type back-light is used. (CCFLx4) Without inverter. For details on dimensions, see dimensional outline drawing. (Figure 20-1,2) Excluding inverter.
Display Resolution	(1280x3)x1024	—	
Display Dot Area	376.32x301.056	mm	
Dot Pitch	(0.098x3)x0.294	mm	
Pixel Aspect Ratio	1:1	—	
Weight	2,800 MAX.	g	
FG-SG	Short circuit	—	

DOCUMENT CONTROL SECTION

DATE

					TITLE		LQ190E1LW01 (FLC48SXC8V-11AA)	
					DRAW. NO.		LD17443	
							CUST.	
EDIT	DATE	DESIG.	CHECK	APPR.	DESCRIPTION			
DESIG.			CHECK		SHARP CORPORATION			
							4/	

6. ABSOLUTE MAXIMUM RATING

Table 6-1 shows the absolute maximum rating of this LCD module.

Table 6-1 Absolute Maximum Rating

Item	Symbol	Condition	MIN.	TYP.	MAX.	Unit
Supply Voltage	V _{CC}	Ta=25°C	-0.3	—	6.0	V
Input Signal Voltage (LVDS signal, PD,SEL LVDS)	V _{IN}	Ta=25°C	-0.3	—	3.6	V

7. RECOMMENDED OPERATING CONDITIONS

Table 7-1 shows the recommended operating conditions of this LCD module.

Table 7-1 Recommended Operating Conditions

Item	Symbol	MIN.	TYP.	MAX.	Unit
Supply Voltage(Logic)	V _{CC}	4.75	—	5.25	V
Ripple Voltage	V _{CC} V _{RP}	—	—	0.1	V

DATE DOCUMENT CONTROL SECTION

						TITLE	LQ190E1LW01 (FLC48SXC8V-11AA)	
						DRAW. NO.	LD17443	CUST.
EDIT	DATE	DESIG.	CHECK	APPR.	DESCRIPTION	SHARP CORPORATION		5/
DESIG.			CHECK		APPR.			

8. ELECTRICAL SPECIFICATIONS

Table 8-1 shows the electrical specifications of this LCD module. Figure 8-1 shows the measurement circuit. Figure 8-2(A) shows the equivalent circuit of the logic signal input area. Figure 8-2(B) shows the equivalent circuit of the supply voltage Input area.

Table 8-1 Electrical Specifications

Item	Symbol	Condition	MIN.	TYP.	MAX.	Unit	Remark
Differential-input Voltage (Hign)	V _{IH}	V _{CM} =+1.2V	—	—	100	mV	
Differential-input Voltage (Low)	V _{IL}		-100	—	—	mV	
Input Voltage (High)	V _{IH}	V _{CC} =+5.0±0.25V V _{SS} =0V DCLK=54MHz Ta=25° C	2.0	—	3.3	V	PD SEL LVDS
Input Voltage (Low)	V _{IL}		0	—	0.8	V	
Supply Current	I _{CC}		—	900	1500	mA	*1
Supply Rush Current	I _{SCC}		—	—	3.5	A	*2
Supply Rush Current Duration(1.5A excess)	T _{SCC}	—	—	1.0	ms		
BACK LIGHT	CCFL Turn on Voltage	V _S	f _L =50kHz, Ta=25°C	—	1400	1600	Vrms
			f _L =50kHz, Ta=0°C	—	1500	1600	
D	Lighting Voltage	V _L	f _L =50kHz I _L =7mA	—	750	—	Vrms
	Lighting Frequency	f _L	V _L =750Vrms	40	50	60	kHz
	Tube Current	I _L	f _L =50kHz V _L =750Vrms	4	7	8	mArms *4

(*1) Typical current situation : Color bar pattern. V_{CC}=5.0V
 Maximum current situation : White pattern. V_{CC}=4.75V
 Without rush current.

(*2) These items prescribe the rush current for starting internal DC/DC.
 Charging current to capacitors of V_{CC} is not prescribed.

(*3) Back-light specifications are valid when using a suitable inverter such as the LQ0DDJ5006 (FLCV-13)

(*4) Tube current (I_L) shows the value of the current that is consumed at one lamp.
 This LCD module has 4 lamps. Each 2 lamps are placed at upper side and lower side of the display.
 2 lamps is connected in parallel. Each low voltage terminals are connected with separate cable to Back-light connector.

DOCUMENT CONTROL SECTION

DATE

						TITLE		LQ190E1LW01	
								(FLC48SXC8V-11AA)	
						DRAW. NO.		LD17443	
								CUST.	
EDIT	DATE	DESIG.	CHECK	APPR.	DESCRIPTION				
DESIG.			CHECK		SHARP CORPORATION				
								6/	

Measurement circuit is based on Figure 8-1.

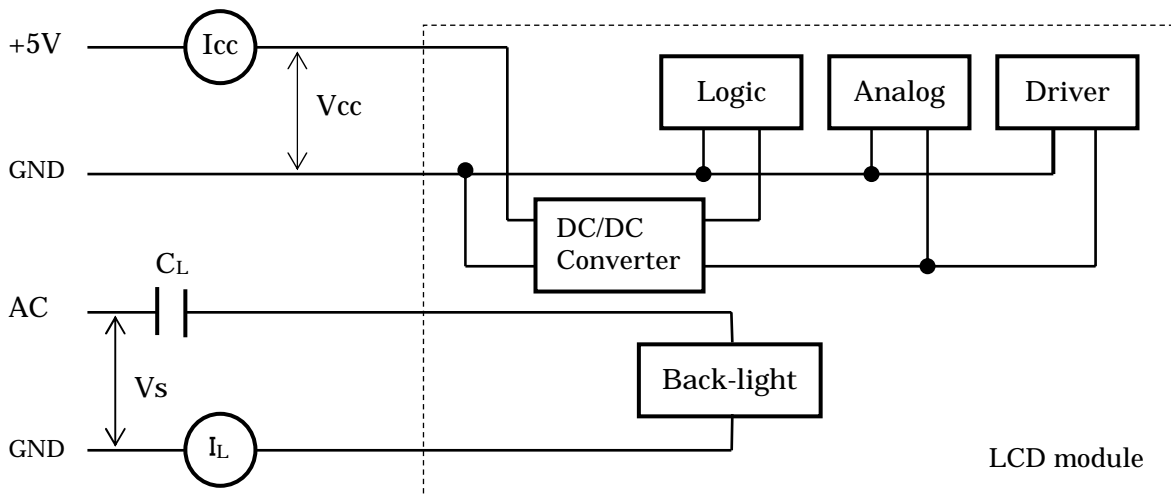

Figure 8-1 Measurement circuit

Input signals (LVDS Dual)

- RX00+ RXE0+
- RX00- RXE0-
- RX01+ RXE1+
- RX01- RXE1-
- RX02+ RXE2+
- RX02- RXE2-
- RX03+ RXE3+
- RX03- RXE3-
- RXOC+ RXEC+
- RXOC- RXEC-

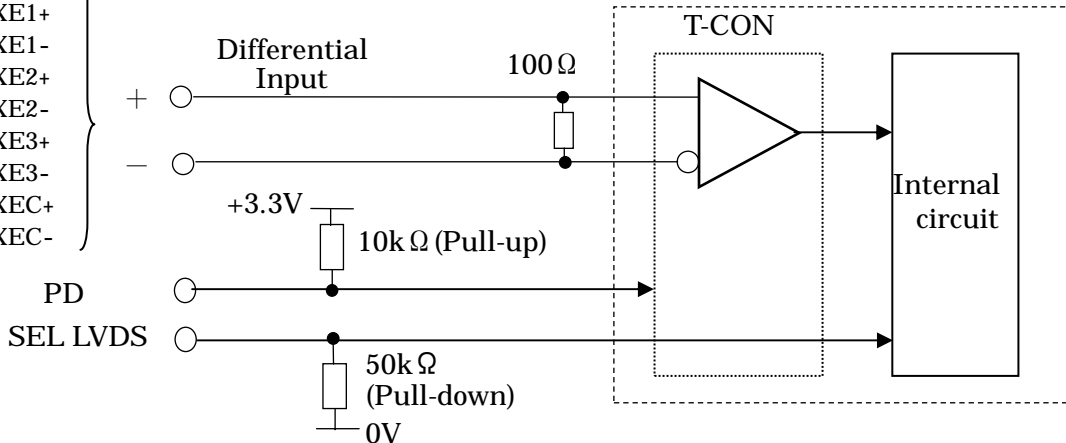

Figure 8-2(A) Equivalent circuit of logic signal Input

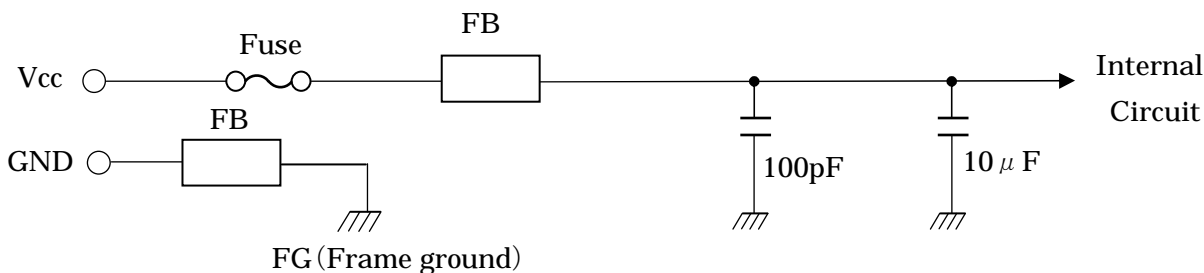

Figure 8-2(B) Equivalent circuit of power supply

DOCUMENT CONTROL SECTION

DATE

EDIT	DATE	DESIG.	CHECK	APPR.	DESCRIPTION
DESIG.			CHECK		APPR.

TITLE	LQ190E1LW01 (FLC48SXC8V-11AA)	
DRAW. NO.	LD17443	CUST.
SHARP CORPORATION		7/

9. OPTICAL SPECIFICATIONS

Table 9-1 shows the optical specifications of this LCD module.

Table 9-1 Optical Specifications

Ta=25°C, Signal timing=Typ.

Item	Symbol	Condition	Specifications			Unit	Remark			
			MIN.	TYP.	MAX.			Note		
Visual Angle	Horizontal	$\theta_{L,R}$	CR \geq 10	$\theta_{U,D}=0^\circ$	85	—	—	deg	(1)(2) (3)(5) (6)	
	Vertical	$\theta_{U,D}$		$\theta_{L,R}=0^\circ$	85	—	—	deg		
	All Direction	θ		—	80	—	—	deg		
Contrast Ratio	CR	$\theta_{L,R,U,D}=0^\circ$		400	700	—	—	White/Black	(1)(2) (3)(5)	
Response Time(Rise+Fall) (B→W→B)	$\tau_{rise} + \tau_{fall}$	$\theta_{L,R,U,D}=0^\circ$	Ta=25°C	—	16	—	—	ms	(1) (4) (5)	
			Ta=0°C	—	34	—	—	ms		
Response Time (Rise or Fall) (All gray scale)	τ_{avg}	$\theta_{L,R,U,D}=0^\circ$	Ta=25°C	—	10	—	—	ms	Average of Response Time, *2	
Brightness	I	$\theta_{L,R,U,D}=0^\circ$		210	300	—	—	cd/m ²	White *1	(1)(5)
Brightness Uniformity	ΔI	$V_{CC}=5V$ $I_L=7mA$ $fL=50kHz$ R*,G*,B* Signal =All "H"		70	—	—	—	%		(1)(5) (7)
Chromaticity	W	x		0.283	0.313	0.343	—	—		(1) (5)
		y		0.299	0.329	0.359	—	—		
	R G B	(x, y)		Red	(0.640, 0.349) Typ.			—	—	
				Green	(0.283, 0.598) Typ.			—	—	
Blue			(0.142, 0.071) Typ.			—	—			
LCD Panel Type				TFT Color						
Display Mode				Normaly Black						
Wide Viewing Angle Technology				MVA						
Optimum Viewing Angle				— (symmentry)			(6)			
Display Color				16,777,216 (8-bit color)						
Color of non-display area				Black						
Surface Treatment				Anti-glare(Haze value:(25%), 2H)						

(*1) Value at 15~20 minutes after lighting on.

(*2) In case of applying FLCB-12, (First Response Time Driving Circuit)

(Note) •CS-1000 (MINOLTA Co., Ltd.) Field=1°, L=500mm

•Back-light current = 7mA, Dark room condition(1 lux or less)

Be carefull that the luminance meter, which you use, may not be able to get correct brightenss if it's no set correctly.

DOCUMENT CONTROL SECTION

DATE

					TITLE		LQ190E1LW01	
05	20040802				Revise of Response time.		(FLC48SXC8V-11AA)	
04	20040708				Revise of Response time.		DRAW. NO.	
03	20040625				Addition of Response time.		LD17443	
EDIT	DATE	DESIG.	CHECK	APPR.	DESCRIPTION		SHARP CORPORATION	
	DESIG.		CHECK		APPR.		8 /	

Note 1) Definition of Viewing Angle (1)

Based on Figure 9-1.

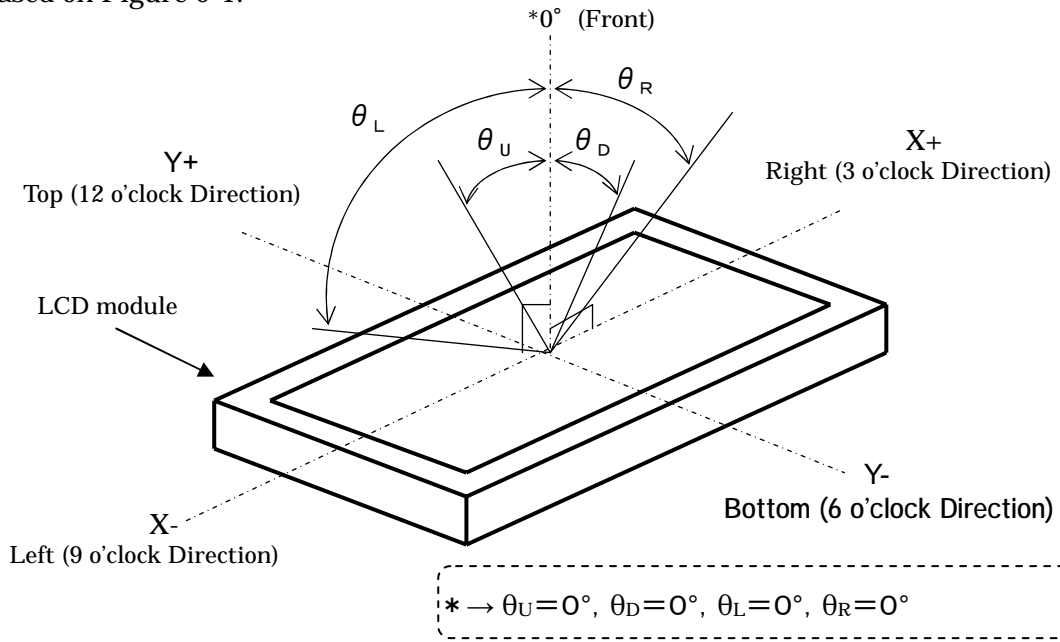

Figure 9-1 Definition of Viewing Angle (1)

Note 2) Definition of Viewing Angle (2)

Based on Figure 9-2.

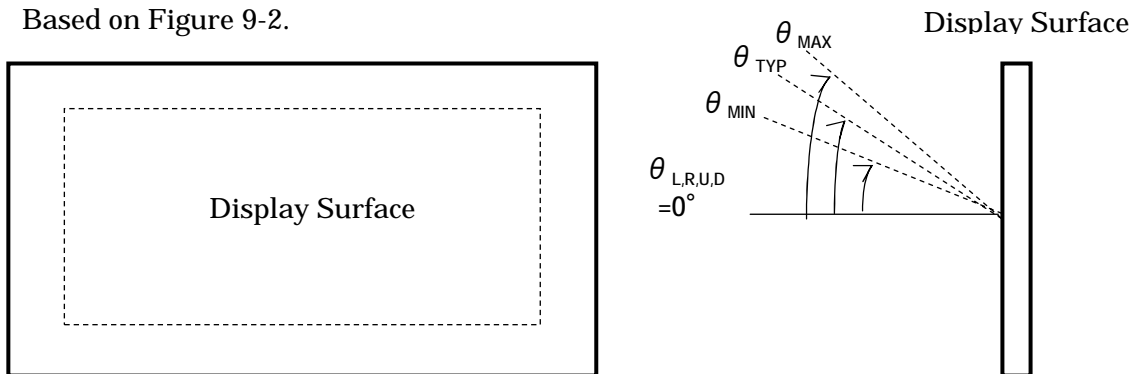

Figure 9-2 Definition of Viewing Angle (2)

Note 3) Definition of Contrast Ratio (CR)

Determined by Formula (1) based on Figure 9-3 Voltage-Brightness characteristics.

$$CR = \frac{L_W \text{ (Brightness at white)}}{L_B \text{ (Brightness at black)}} \dots\dots(1)$$

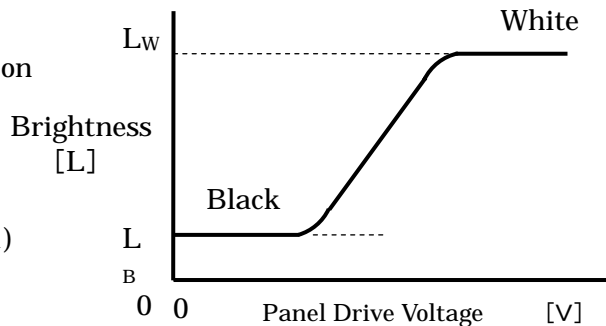

Figure 9-3 Voltage-Brightness Characteristics

DOCUMENT CONTROL SECTION
DATE

						TITLE		LQ190E1LW01	
								(FLC48SXC8V-11AA)	
						DRAW. NO.		LD17443	
								CUST.	
EDIT	DATE	DESIG.	CHECK	APPR.	DESCRIPTION				
DESIG.				CHECK				SHARP CORPORATION	
								9 /	

Note 4) Definition of Response Time

Based on Figure 9-4.

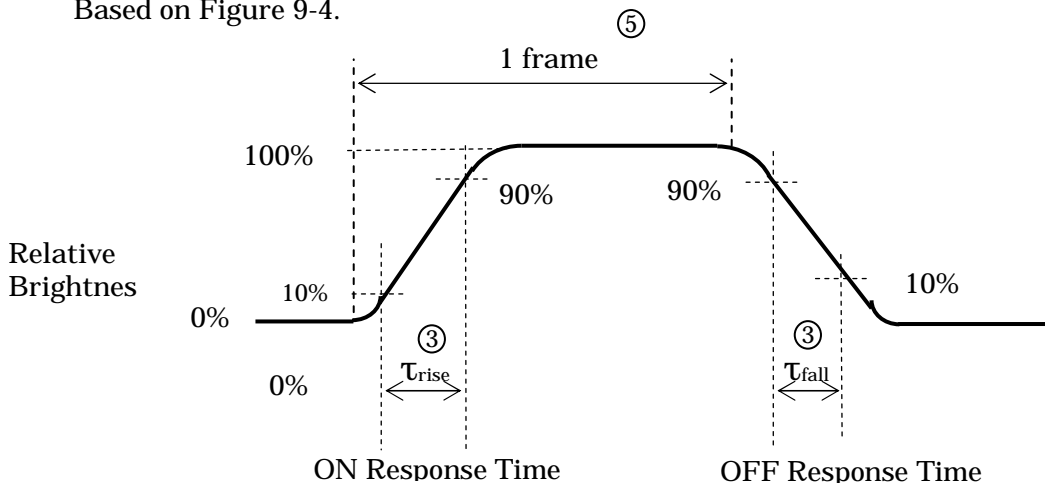

Figure 9-4 Definition of Response Time

Note 5) Contrast Ratio and Response Measurement System

Based on Figure 9-5.

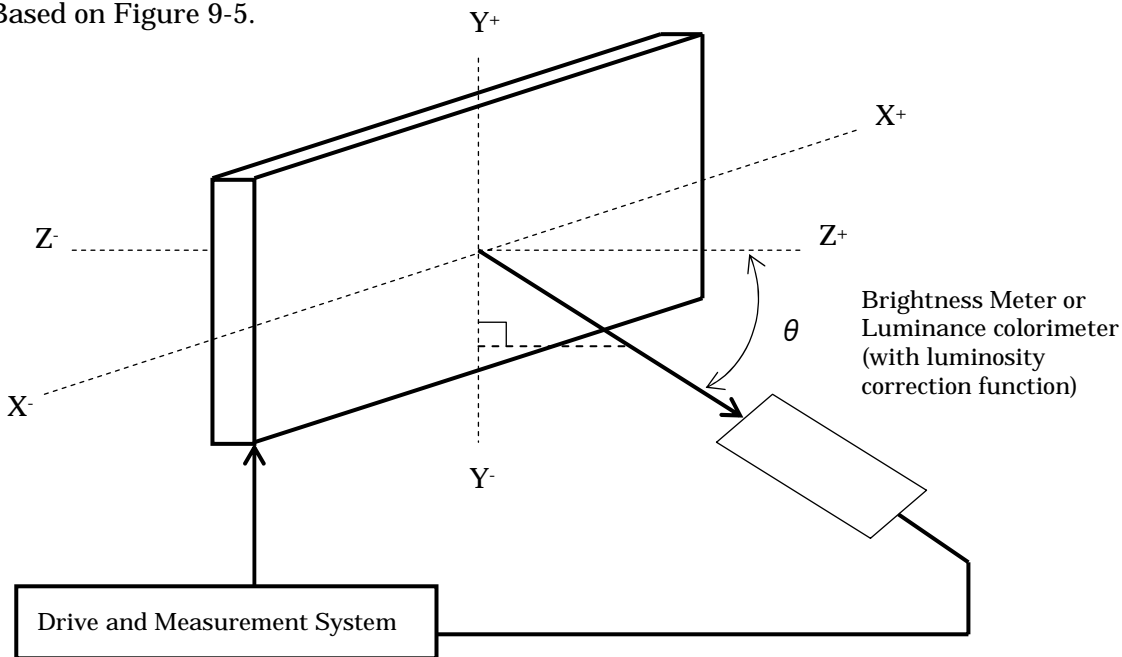

Figure 9-5 Contrast Ratio and Response Time Measurement System

DATE	DOCUMENT CONTROL SECTION				

						TITLE	LQ190E1LW01 (FLC48SXC8V-11AA)	
05	20040802				Addition of response time definition.	DRAW. NO.	LD17443	CUST.
03	20040625				Change response time definition.			
02	20040602				Change response time definition.			
EDIT	DATE	DESIG.	CHECK	APPR.	DESCRIPTION	SHARP CORPORATION		10/
DESIG.			CHECK					

Note 6) Definition of Optimum Viewing Angle

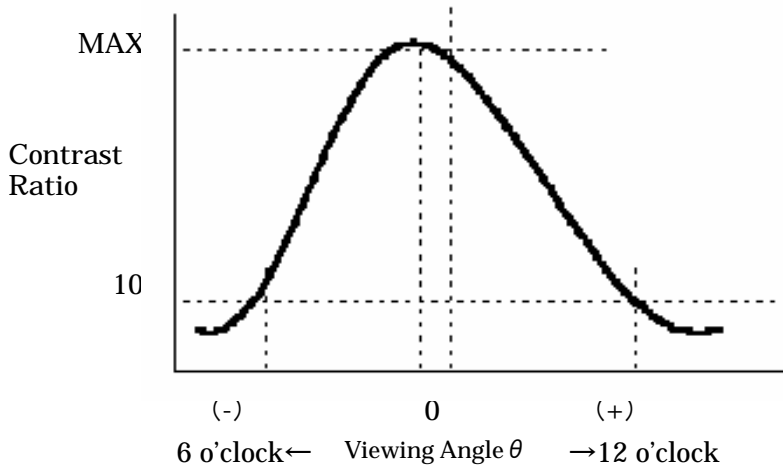

Figure 9-6 Definition of Viewing Angle

Note 7) Definition of Brightness Uniformity

Brightness uniformity is defined by the following formula.

Brightness (I1~I9) are measured at the following 9 points (①-⑨) on the display area that is shown in Figure 9-7.

$$\text{Brightness Uniformity } (\Delta L) = \frac{|\text{Min. In }|}{|\text{Max. In }|} \times 100 (\%) , n = 1 \text{ to } 9$$

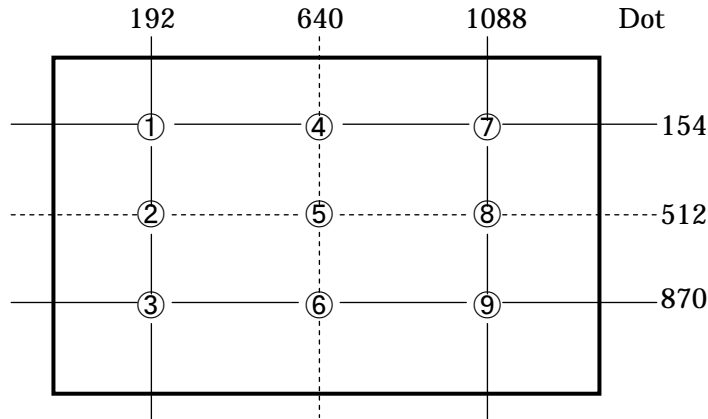

Note) Each measurement point (①-⑨) defines the center spot of view of Brightness Meter. The tolerance of measurement position is $\pm 3\text{mm}$.

Figure 9-7 Measurement Points

DOCUMENT CONTROL SECTION

DATE

						TITLE		LQ190E1LW01	
								(FLC48SXC8V-11AA)	
						DRAW. NO.		LD17443	
								CUST.	
EDIT	DATE	DESIG.	CHECK	APPR.	DESCRIPTION				
DESIG.			CHECK		SHARP CORPORATION				
				APPR.				11/	

10. INTERFACE SPECIFICATIONS

10-1 Signal descriptions

Table 10-1 shows the description and configuration of interface signals (CN1).

Table 10-1 Interface signals (CN1)

Pin No.	Symbol	I/O	Function
1	RxO0-	I	Negative differential input
2	RxO0+	I	Positive differential input
3	RxO1-	I	Negative differential input
4	RxO1+	I	Positive differential input
5	RxO2-	I	Negative differential input
6	RxO2+	I	Positive differential input
7	GND	—	Ground
8	RxOC-	I	Negative differential input
9	RxOC+	I	Positive differential input
10	RxO3-	I	Negative differential input
11	RxO3+	I	Positive differential input
12	RxE0-	I	Negative differential input
13	RxE0+	I	Positive differential input
14	GND	—	Ground
15	RxE1-	I	Negative differential input
16	RxE1+	I	Positive differential input
17	GND	—	Ground
18	RxE2-	I	Negative differential input
19	RxE2+	I	Positive differential input
20	RxEC-	I	Negative differential input
21	RxEC+	I	Positive differential input
22	RxE3-	I	Negative differential input
23	RxE3+	I	Positive differential input
24	GND	—	Ground
25	SEL LVDS	I	Select LVDS Mapping
26	PD	—	LVDS Core Power Down
27	TST	—	Test pin *1
28	Vcc	—	+5V power supply
29	Vcc	—	+5V power supply
30	Vcc	—	+5V power supply

Connector : FI-X30SSL-HF (Japan Aviation Electronics)

User's connector : FI-X30M (FPC type)

FI-X30H (Wire type) , FI-X30HL (Wire with lock)

FI-X30C (Coaxial cable type) , FI-X30C2L (Coaxial cable with lock)

*1: Keep open. (Internal test use only.)

*2: When using a connector other than the recommended one , a defect in the initial stage or a problem concerning long term reliability may occur.

DOCUMENT CONTROL SECTION

DATE

						TITLE		LQ190E1LW01	
								(FLC48SXC8V-11AA)	
						DRAW. NO.		LD17443	
								CUST.	
EDIT	DATE	DESIG.	CHECK	APPR.	DESCRIPTION				
DESIG.			CHECK		SHARP CORPORATION				
								12/	

10-2 LVDS Data Assignment

Table 10-2A,10-2B show the LVDS Data Assignment.

Table 10-2A LVDS Data Assignment(SEL LVDS=L)

Input signal *1		Transmitter DS90CF383,C385		Interface connector			Receiver DS90CF386 THC63LVDF84		LCD Control input			
		pin	INPUT	System side	LCD module		pin	OUTPUT				
					pin							
LVDS Odd	RO2	51	TxIN0	Tx OUT0+	2	RxO0+	27	RxOUT0	RO2			
	RO3	52	TxIN1				29	RxOUT1	RO3			
	RO4	54	TxIN2				30	RxOUT2	RO4			
	RO5	55	TxIN3				32	RxOUT3	RO5			
	RO6	56	TxIN4				33	RxOUT4	RO6			
	RO7	3	TxIN6	Tx OUT0-	1	RxO0-	35	RxOUT6	RO7			
	GO2	4	TxIN7				37	RxOUT7	GO2			
	GO3	6	TxIN8				38	RxOUT8	GO3			
	GO4	7	TxIN9				Tx OUT1+	4	RxO1+	39	RxOUT9	GO4
	GO5	11	TxIN12							43	RxOUT12	GO5
	GO6	12	TxIN13	45	RxOUT13	GO6						
	GO7	14	TxIN14	Tx OUT1-	3	RxO1-				46	RxOUT14	GO7
	BO2	15	TxIN15							47	RxOUT15	BO2
	BO3	19	TxIN18				51	RxOUT18	BO3			
	BO4	20	TxIN19				Tx OUT2+	6	RxO2+	53	RxOUT19	BO4
	BO5	22	TxIN20							54	RxOUT20	BO5
	BO6	23	TxIN21	55	RxOUT21	BO6						
	BO7	24	TxIN22	1	RxOUT22	BO7						
	RSVD	27	TxIN24	Tx OUT2-	5	RxO2-				3	RxOUT24	Not use
	RSVD	28	TxIN25				5	RxOUT25	Not use			
	ENAB	30	TxIN26				6	RxOUT26	ENAB			
	RO0	50	TxIN27				7	RxOUT27	RO0			
	RO1	2	TxIN5				Tx OUT3+	11	RxO3+	34	RxOUT5	RO1
	GO0	8	TxIN10	41	RxOUT10	GO0						
	GO1	10	TxIN11	42	RxOUT11	GO1						
BO0	16	TxIN16	Tx OUT3-	10	RxO3-	49				RxOUT16	BO0	
BO1	18	TxIN17				50				RxOUT17	BO1	
RSVD	25	TxIN23				2	RxOUT23	Not use				
DCLK	31	TxCLK IN				TxCLK OUT+	9	RxCLK IN+	26	RxCLK OUT	DCLK	
						TxCLK OUT-	8	RxCLK IN-				
LVDS Even	RE2	51	TxIN0	Tx OUT0+	13	RxEO+	27	RxOUT0	RE2			
	RE3	52	TxIN1				29	RxOUT1	RE3			
	RE4	54	TxIN2				30	RxOUT2	RE4			
	RE5	55	TxIN3				32	RxOUT3	RE5			
	RE6	56	TxIN4				33	RxOUT4	RE6			
	RE7	3	TxIN6	Tx OUT0-	12	RxEO-	35	RxOUT6	RE7			
	GE2	4	TxIN7				37	RxOUT7	GE2			
	GE3	6	TxIN8				Tx OUT1+	16	RxE1+	38	RxOUT8	GE3
	GE4	7	TxIN9							39	RxOUT9	GE4
	GE5	11	TxIN12							43	RxOUT12	GE5
	GE6	12	TxIN13	45	RxOUT13	GE6						
	GE7	14	TxIN14	Tx OUT1-	15	RxE1-				46	RxOUT14	GE7
	BE2	15	TxIN15				47	RxOUT15	BE2			
	BE3	19	TxIN18				51	RxOUT18	BE3			
	BE4	20	TxIN19				Tx OUT2+	19	RxE2+	53	RxOUT19	BE4
	BE5	22	TxIN20							54	RxOUT20	BE5
	BE6	23	TxIN21	55	RxOUT21	BE6						
	BE7	24	TxIN22	1	RxOUT22	BE7						
	RSVD	27	TxIN24	Tx OUT2-	18	RxE2-				3	RxOUT24	Not use
	RSVD	28	TxIN25				5	RxOUT25	Not use			
	RSVD	30	TxIN26				6	RxOUT26	Not use			
	RE0	50	TxIN27				7	RxOUT27	RE0			
	RE1	2	TxIN5				Tx OUT3+	23	RxE3+	34	RxOUT5	RE1
	GE0	8	TxIN10	41	RxOUT10	GE0						
	GE1	10	TxIN11	42	RxOUT11	GE1						
BE0	16	TxIN16	Tx OUT3-	22	RxE3-	49				RxOUT16	BE0	
BE1	18	TxIN17				50				RxOUT17	BE1	
RSVD	25	TxIN23				2	RxOUT23	Not use				
DCLK	31	TxCLK IN				TxCLK OUT+	21	RxCLK IN+	26	RxCLK OUT	Not use	
						TxCLK OUT-	20	RxCLK IN-				

*1 ·RSVD (reserved) pin on a transmitter should be connected with Ground.

·Input odd or even data depending on the display position of the LCD module.

DOCUMENT CONTROL SECTION

DATE

						TITLE		LQ190E1LW01	
								(FLC48SXC8V-11AA)	
						DRAW. NO.		LD17443	
								CUST.	
EDIT	DATE	DESIG.	CHECK	APPR.	DESCRIPTION				
DESIG.			CHECK		SHARP CORPORATION				
								13/	

Table 10-2B LVDS Data Assignment(SEL LVDS=H)

Input signal *1		Transmitter DS90CF383,C385		Interface connector			Receiver DS90CF386 THC63LVDF84		LCD Control input		
		pin	INPUT	System side	LCD module		pin	OUTPUT			
					pin						
LVDS Odd	RO0	51	TxIN0	Tx OUT0+	2	RxO0+	27	RxOUT0	RO0		
	RO1	52	TxIN1				29	RxOUT1	RO1		
	RO2	54	TxIN2				30	RxOUT2	RO2		
	RO3	55	TxIN3				32	RxOUT3	RO3		
	RO4	56	TxIN4				33	RxOUT4	RO4		
	RO5	3	TxIN6	Tx OUT0-	1	RxO0-	35	RxOUT6	RO5		
	GO0	4	TxIN7				37	RxOUT7	GO0		
	GO1	6	TxIN8				38	RxOUT8	GO1		
	GO2	7	TxIN9				39	RxOUT9	GO2		
	GO3	11	TxIN12				43	RxOUT12	GO3		
	GO4	12	TxIN13	Tx OUT1+	4	RxO1+	45	RxOUT13	GO4		
	GO5	14	TxIN14				46	RxOUT14	GO5		
	BO0	15	TxIN15				47	RxOUT15	BO0		
	BO1	19	TxIN18				51	RxOUT18	BO1		
	BO2	20	TxIN19				53	RxOUT19	BO2		
	BO3	22	TxIN20	Tx OUT2+	6	RxO2+	54	RxOUT20	BO3		
	BO4	23	TxIN21				55	RxOUT21	BO4		
	BO5	24	TxIN22				1	RxOUT22	BO5		
	RSVD	27	TxIN24				3	RxOUT24	Not use		
	RSVD	28	TxIN25				5	RxOUT25	Not use		
	ENAB	30	TxIN26	6	RxOUT26	ENAB					
	RO6	50	TxIN27	Tx OUT2-	5	RxO2-	7	RxOUT27	RO6		
	RO7	2	TxIN5				34	RxOUT5	RO7		
	GO6	8	TxIN10				41	RxOUT10	GO6		
	GO7	10	TxIN11				42	RxOUT11	GO7		
BO6	16	TxIN16	49				RxOUT16	BO6			
BO7	18	TxIN17	Tx OUT3-	10	RxO3-	50	RxOUT17	BO7			
RSVD	25	TxIN23				2	RxOUT23	Not use			
DCLK	31	TxCLK IN	TxCLK OUT+	9	RxCLK IN+	26	RxCLK OUT	DCLK			
			TxCLK OUT-	8	RxCLK IN-						
LVDS Even	RE0	51	TxIN0	Tx OUT0+	13	RxE0+	27	RxOUT0	RE0		
	RE1	52	TxIN1				29	RxOUT1	RE1		
	RE2	54	TxIN2				30	RxOUT2	RE2		
	RE3	55	TxIN3				32	RxOUT3	RE3		
	RE4	56	TxIN4				33	RxOUT4	RE4		
	RE5	3	TxIN6	Tx OUT0-	12	RxE0-	35	RxOUT6	RE5		
	GE0	4	TxIN7				37	RxOUT7	GE0		
	GE1	6	TxIN8				38	RxOUT8	GE1		
	GE2	7	TxIN9				39	RxOUT9	GE2		
	GE3	11	TxIN12				43	RxOUT12	GE3		
	GE4	12	TxIN13	Tx OUT1+	16	RxE1+	45	RxOUT13	GE4		
	GE5	14	TxIN14				46	RxOUT14	GE5		
	BE0	15	TxIN15				47	RxOUT15	BE0		
	BE1	19	TxIN18				51	RxOUT18	BE1		
	BE2	20	TxIN19				53	RxOUT19	BE2		
	BE3	22	TxIN20	Tx OUT2+	19	RxE2+	54	RxOUT20	BE3		
	BE4	23	TxIN21				55	RxOUT21	BE4		
	BE5	24	TxIN22				1	RxOUT22	BE5		
	RSVD	27	TxIN24				3	RxOUT24	Not use		
	RSVD	28	TxIN25				5	RxOUT25	Not use		
	RSVD	30	TxIN26	6	RxOUT26	Not use					
	RE6	50	TxIN27	Tx OUT2-	18	RxE2-	7	RxOUT27	RE6		
	RE7	2	TxIN5				34	RxOUT5	RE7		
	GE6	8	TxIN10				41	RxOUT10	GE6		
	GE7	10	TxIN11				42	RxOUT11	GE7		
BE6	16	TxIN16	Tx OUT3+				23	RxE3+	49	RxOUT16	BE6
BE7	18	TxIN17		Tx OUT3-	22	RxE3-			50	RxOUT17	BE7
RSVD	25	TxIN23							2	RxOUT23	Not use
DCLK	31	TxCLK IN	TxCLK OUT+	21	RxCLK IN+	26	RxCLK OUT	Not use			
			TxCLK OUT-	20	RxCLK IN-						

*1 ·RSVD (reserved) pin on a transmitter should be connected with Ground.
 ·Input odd or even pin data depending on the display position of the LCD module.

DOCUMENT CONTROL SECTION

DATE

						TITLE LQ190E1LW01 (FLC48SXC8V-11AA)			
						DRAW. NO. LD17443			CUST.
						SHARP CORPORATION			
						14/			
EDIT	DATE	DESIG.	CHECK	APPR.	DESCRIPTION				
DESIG.			CHECK		APPR.				

10-3 Color Data Assignment

Table 10-3 shows the Color Data Assignment.

Table 10-3 Color Data Assignment

Color		R Input data								G Input data								B Input data								
	Odd	R7	R6	R5	R4	R3	R2	R1	R0	G7	G6	G5	G4	G3	G2	G1	G0	B7	B6	B5	B4	B3	B2	B1	B0	
	Even	R7	R6	R5	R4	R3	R2	R1	R0	G7	G6	G5	G4	G3	G2	G1	G0	B7	B6	B5	B4	B3	B2	B1	B0	
Basic Color	Black	0	0	0	0	0	0	0	0	0	0	0	0	0	0	0	0	0	0	0	0	0	0	0	0	
	Blue	0	0	0	0	0	0	0	0	0	0	0	0	0	0	0	0	1	1	1	1	1	1	1	1	
	Green	0	0	0	0	0	0	0	0	1	1	1	1	1	1	1	1	0	0	0	0	0	0	0	0	
	Cyan	0	0	0	0	0	0	0	0	1	1	1	1	1	1	1	1	1	1	1	1	1	1	1	1	
	Red	1	1	1	1	1	1	1	1	0	0	0	0	0	0	0	0	0	0	0	0	0	0	0	0	
	Magenta	1	1	1	1	1	1	1	1	0	0	0	0	0	0	0	0	1	1	1	1	1	1	1	1	
	Yellow	1	1	1	1	1	1	1	1	1	1	1	1	1	1	1	1	0	0	0	0	0	0	0	0	
	White	1	1	1	1	1	1	1	1	1	1	1	1	1	1	1	1	1	1	1	1	1	1	1	1	
Red	Black	0	0	0	0	0	0	0	0	0	0	0	0	0	0	0	0	0	0	0	0	0	0	0	0	
	↑	1	0	0	0	0	0	0	0	1	0	0	0	0	0	0	0	0	0	0	0	0	0	0	0	0
	↑	:	:	:	:	:	:	:	:	:	:	:	:	:	:	:	:	:	:	:	:	:	:	:	:	
	:	:	:	:	:	:	:	:	:	:	:	:	:	:	:	:	:	:	:	:	:	:	:	:	:	
	↓	:	:	:	:	:	:	:	:	:	:	:	:	:	:	:	:	:	:	:	:	:	:	:	:	
	Brighter	253	1	1	1	1	1	1	0	1	0	0	0	0	0	0	0	0	0	0	0	0	0	0	0	0
	↓	254	1	1	1	1	1	1	1	0	0	0	0	0	0	0	0	0	0	0	0	0	0	0	0	0
Red	255	1	1	1	1	1	1	1	1	0	0	0	0	0	0	0	0	0	0	0	0	0	0	0	0	
Green	Black	0	0	0	0	0	0	0	0	0	0	0	0	0	0	0	0	0	0	0	0	0	0	0	0	
	↑	1	0	0	0	0	0	0	0	0	0	0	0	0	0	0	0	1	0	0	0	0	0	0	0	0
	↑	:	:	:	:	:	:	:	:	:	:	:	:	:	:	:	:	:	:	:	:	:	:	:	:	
	:	:	:	:	:	:	:	:	:	:	:	:	:	:	:	:	:	:	:	:	:	:	:	:	:	
	↓	:	:	:	:	:	:	:	:	:	:	:	:	:	:	:	:	:	:	:	:	:	:	:	:	
	Brighter	253	0	0	0	0	0	0	0	0	1	1	1	1	1	1	0	1	0	0	0	0	0	0	0	0
	↓	254	0	0	0	0	0	0	0	0	1	1	1	1	1	1	1	0	0	0	0	0	0	0	0	0
Green	255	0	0	0	0	0	0	0	0	1	1	1	1	1	1	1	1	0	0	0	0	0	0	0	0	
Blue	Black	0	0	0	0	0	0	0	0	0	0	0	0	0	0	0	0	0	0	0	0	0	0	0	0	
	↑	1	0	0	0	0	0	0	0	0	0	0	0	0	0	0	0	0	0	0	0	0	0	0	0	1
	↑	:	:	:	:	:	:	:	:	:	:	:	:	:	:	:	:	:	:	:	:	:	:	:	:	
	:	:	:	:	:	:	:	:	:	:	:	:	:	:	:	:	:	:	:	:	:	:	:	:	:	
	↓	:	:	:	:	:	:	:	:	:	:	:	:	:	:	:	:	:	:	:	:	:	:	:	:	
	Brighter	253	0	0	0	0	0	0	0	0	0	0	0	0	0	0	0	0	1	1	1	1	1	1	0	1
	↓	254	0	0	0	0	0	0	0	0	0	0	0	0	0	0	0	0	1	1	1	1	1	1	1	0
Blue	255	0	0	0	0	0	0	0	0	0	0	0	0	0	0	0	0	1	1	1	1	1	1	1	1	

Note.1) Definition of gray scale:Color (n)...”n” indicates gray scale level.

Larger number means brighter level.

Note.2) Data; 1:High, 0:Low

Note 3) Color data consist of 8 bit red, green and blue data of odd and even number pixel data. Total data number is 48 signals. This module is able to display 16,777,216 colors because each red, green and blue data is controlled independently.

DOCUMENT CONTROL SECTION

						TITLE		LQ190E1LW01			
								(FLC48SXC8V-11AA)			
						DRAW. NO.		LD17443			
								CUST.			
EDIT	DATE	DESIG.	CHECK	APPR.	DESCRIPTION		SHARP CORPORATION				
DESIG.			CHECK		APPR.		DATE		15/		

10-4 Input Signal Timing

Table 10-4 and Figure 10-1 shows the Input Signal Timing at LVDS transmitter.

Table 10-4 Timing Characteristics

(Ta=0~50°C, Vcc=5±0.25V)

Item		Symbol	Min.	Typ.	Max.	Unit	Remark
DCLK signal (Clock)	Period	Tc	14.3	18.5	25.0	ns	
	Frequency	1/Tc	40	54	70	MHz	
	Duty	Tch/Tc	45	50	55	%	
	High time	TclkH	5.0	—	—	ns	
	Low time	TclkL	5.0	—	—	ns	
DCLK-Data Timing	Setup time	Tset	3	—	—	ns	LVDS Tr spec.
	Hold time	Thold	5	—	—	ns	
ENAB signal	Hor. Period (1)	Th	5350/Tc+435	844	887 *1	DCLK	Tc=ns *4
	Hor. Period (2)	Th	648	—	1023	DCLK	*4
	Hor. Display period	Thd	640	640	640	DCLK	*2
	Vertical Period	Tv	1028 *1	1066	1088 *1	Th	16.67ms
	Ver. Frequency	1/Tv	50	60	76.2	Hz	
	Ver. Display period	Tvd	1024	1024	1024	Th	*2
Data-ENAB timing	Tdn	—	0	—	DCLK	*3	

*1) •horizontal display position is specified by the rise of ENAB.
 The data latched at falling edge of DCLK after rise of ENAB is displayed at the left edge of the display area.
 •Vertical display position is specified by the rise of ENAB after low level continuation over 2048 DCLK.
 The data latched at the rise of ENAB is displayed at the top line of the display area.

*2) •If the “High” level period of ENAB is less than 640 DCLK or the number of ENAB in a frame period (Tv) is less than 1024, black color is displayed at the rest of the display area.

*3) •If ENAB does not synchronize with the effective display data, the display position does not fit to the display area.

*4) •Hor. Period (2) shows the operating range where internal circuit can work correctly.
 •When ENAB signal is out of Hor. Period (1), the display quality may deteriorate.

DOCUMENT CONTROL SECTION

DATE

						TITLE		LQ190E1LW01	
								(FLC48SXC8V-11AA)	
						DRAW. NO.		LD17443	
								CUST.	
EDIT	DATE	DESIG.	CHECK	APPR.	DESCRIPTION				
DESIG.			CHECK		SHARP CORPORATION				
								16/	

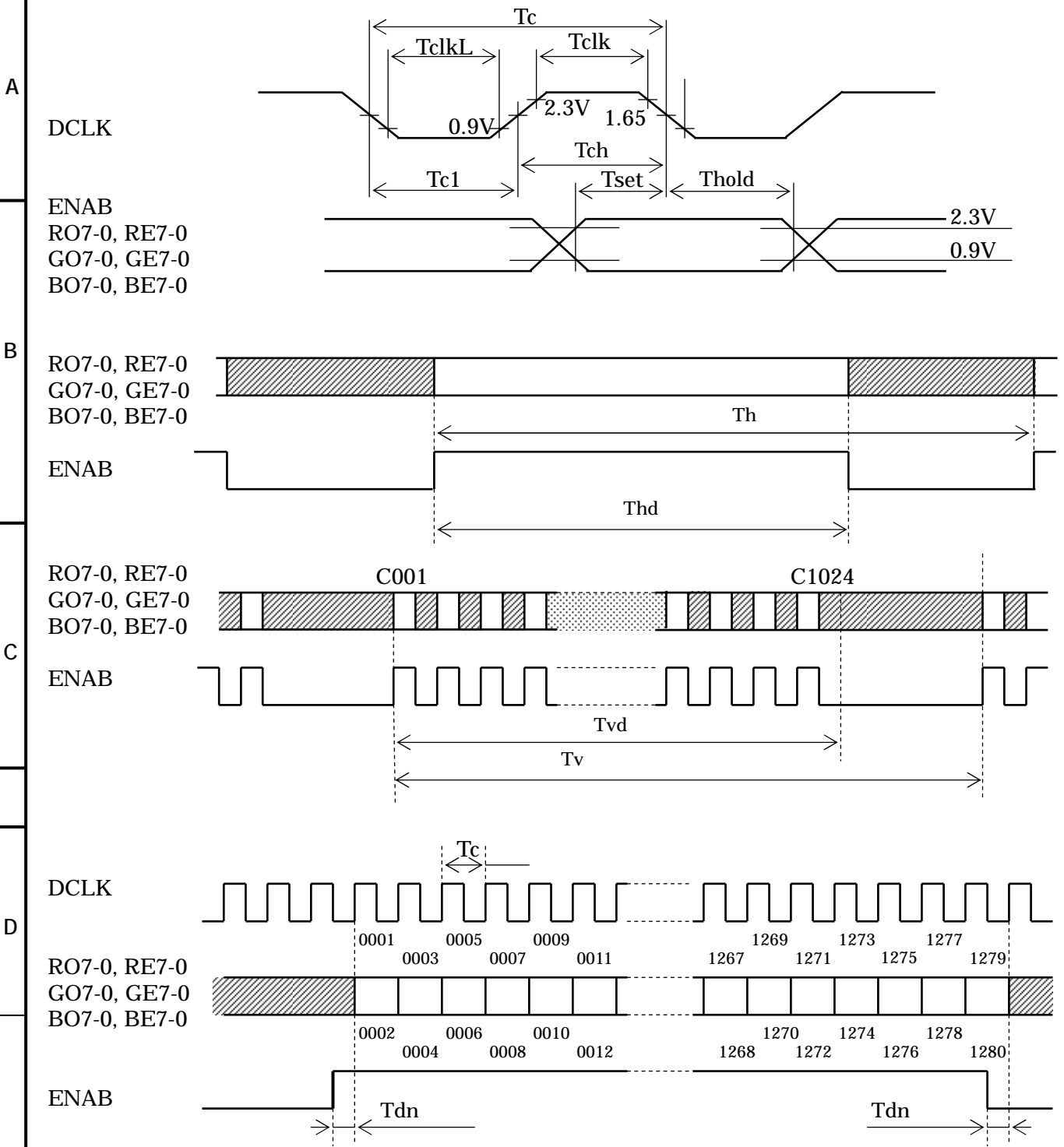

Figure 10-1 Input Signal Timing Chart

DOCUMENT CONTROL SECTION

DATE

					TITLE		LQ190E1LW01	
							(FLC48SXC8V-11AA)	
					DRAW. NO.		LD17443	
							CUST.	
EDIT	DATE	DESIG.	CHECK	APPR.	DESCRIPTION			
DESIG.			CHECK		SHARP CORPORATION			
								17/

10-5 Correspondence between Data and Display Position

Figure 10-2 shows the Correspondence between Data and Display Position.

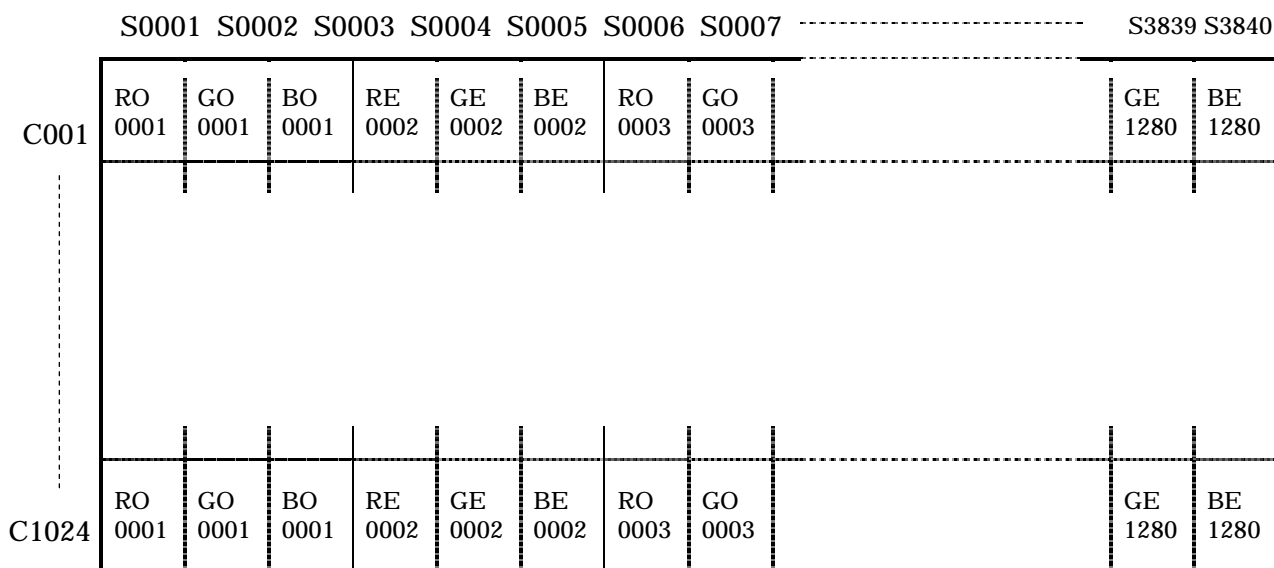
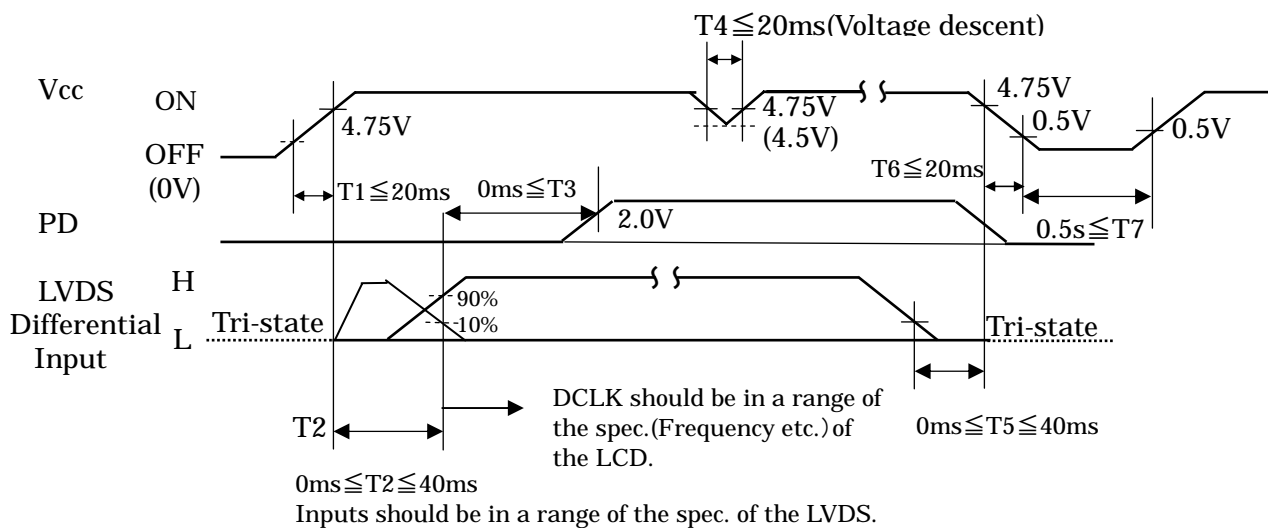

Figure 10-2 Correspondence Data and Display Position

10-5 Power Supply Sequence

The sequence of input signals and On/Off of the power supply of this LCD module should be in the specification shown in Figure 10-3 to prevent latch-up of the driver ICs and DC driving of the LCD panel.



*Note : PD input can be set open, if it is not used.

Figure 10-3 Power Supply Sequence

DOCUMENT CONTROL SECTION

DATE

						TITLE		LQ190E1LW01	
								(FLC48SXC8V-11AA)	
						DRAW. NO.		LD17443	
								CUST.	
EDIT	DATE	DESIG.	CHECK	APPR.	DESCRIPTION				
DESIG.			CHECK		SHARP CORPORATION				
									18/

11. BACK-LIGHT SPECIFICATIONS

11-1 Pin configuration for Back-light

Table 11-1 shows the description and Pin assignment of the connectors (CN-A to D) for the Back-light of this LCD module.

Table 11-1 Pin Assignment of CN-A to CN-D

Pin No.	Signal				Function	Cable color
	CN-A	CN-B	CN-C	CN-D		
1	V _{L1}	V _{L2}	V _{L3}	V _{L4}	Power supply	Pink ,Orange
2	—	—	—	—	—	—
3	GND	GND	GND	GND	Ground	Blue, Gray

Connector : Housing : BHR-03VS-1
 Contact : SBH-001T-P0.5
 User's Connector : Post with base: SM02(8.0)B-BHS-1-TB
 Supplier : Japan Solderless Terminal Trading Company LTD. (J.S.T.)

11-2 Life

The life of the back-light is a minimum of 50,000 hours at the following conditions.

(1) Working conditions

- ①Ambient temperature: 25 ± 5°C
- ②Tube current (I_L) : 7mA or less

(2) Definition of life

- ①Brightness becomes 50% or less than the minimum brightness value shown in Table 9-1.
- ②The lamp cannot be lit by the minimum value of the breakdown voltage(1760Vrms) shown in Table 8-1.
- ③Flashing.

11-4 Lamp assembly set (for replacement)

Lamp assembly set(with charge)is prepared for replacing old lamp to new one. This set consists of a upper lamp assembly and a lower lamp assembly.

Type number : LQ0DDB5467(FLCL-33)

Minimum order qty. unit : 20 pcs.

DATE DOCUMENT CONTROL SECTION

					TITLE LQ190E1LW01 (FLC48SXC8V-11AA)	
					DRAW. NO. LD17443	
					CUST.	
07	20050420				Lamp Assy No. was changed.	
EDIT	DATE	DESIG.	CHECK	APPR.	DESCRIPTION	
					SHARP CORPORATION	
DESIG.			CHECK		19/	

12. APPEARANCE SPECIFICATIONS

12-1 Appearance

No.	Item	Judgment method and standard		
1	Bright spot (high and Low)	≤ 4 dots		(Note 1)
2	Bright spot connection (high and low)	≤ 2 pair (2 dot connection in horizontal only)		(Note 1)
3	Total of bright spot	≤ 4 dots		
4	Dark spot	≤ 8 dots		(Note 2)
5	Dark spot connection	≤ 3 pairs		(Note 2)
6	Total of dark spot	≤ 8 dots		(Note 2)
7	Total of dot defect (bright and dark)	≤ 8 dots		
8	Distance of bright spot	high-hgh	≥ 15 mm	
		others	≥ 5 mm	
9	Distance of dark spot	≥ 5 mm		
10	Scratch on polarizer, line shape	$W \leq 0.03$	—————	Ignore
		$0.03 < W \leq 0.05$	$L \leq 6$	Ignore
			$6 < L \leq 12$	≤ 5
			$12 < L$	0
		$0.05 < W \leq 0.10$	$L \leq 0.6$	Ignore
			$0.6 < L$	0
$0.10 < W$	—————	0		
11	Dent on polarizer, dot shape	$D \leq 0.3$	Ignore	
		$0.3 < D \leq 0.4$	≤ 5	
		$0.4 < D$	0	
12	Bubble in polarizer	$D \leq 0.3$	Ignore	
		$0.3 < D \leq 0.5$	≤ 5	
		$0.5 < D$	0	
13	Black white spot (Foreign circular matter)	$D \leq 0.3$	Ignore	
		$0.3 < D \leq 0.5$	≤ 5	
		$0.5 < D$	0	
14	Light leakage by foreign articles	$D \leq 0.3$	Ignore	
		$0.3 < D \leq 0.6$	≤ 4	
		$0.6 < D$	0	
15	Lints, black/white line	$W \leq 0.03$	—————	Ignore
		$0.03 < W \leq 0.05$	$L \leq 6$	Ignore
			$6 < L \leq 12$	≤ 4
			$12 < L$	0
		$0.05 < W \leq 0.10$	$L \leq 0.6$	Ignore
			$0.6 < L \leq 5$	≤ 2
$0.10 < W$	$5 < L$	0		
		$(W+L)/2=D$	Conform to No.13	
16	Mura	Invisible under 6% ND filter from center of display. (Display pattern : Black, White, 50% gray)		

D:Average diameter [mm], W:Width [mm], L:Length [mm], S=(bright spot size)/(dot size)

DOCUMENT CONTROL SECTION

DATE

					TITLE LQ190E1LW01 (FLC48SXC8V-11AA)	
					DRAW. NO. LD17443	
					CUST.	
EDIT	DATE	DESIG.	CHECK	APPR.	DESCRIPTION	
DESIG.			CHECK		SHARP CORPORATION	
					20/	

12-2 Dot defects (Bright spots, Dark spots)

A

A

12-2-1 Zone

- Inside display dot area (376.32×301.056mm)
- Display dot area means active area.
- One pixel consists of 3 dots (red, green and blue).
- Foreign particle and scratch unharmed to display image, such as the foreign particle under polarizer film but outside of the display area and scratch on metal bezel, backlight module or polarizer film out of the display area, etc., are not counted.

B

B

12-2-2 Bright spots

(1) Bright spots by the defect of TFT.

- Visible under bias of 2% ND filter High bright spot R•G
- Visible under 5% but invisible under 2% ND filter Low bright spot R•G•B
- Invisible under bias of 5% ND filter Not counted

(2) Bright spots by the light passing through tears, breaks, etc in color filter.

- Exceed size of a half dot High bright spot
- A half dot or less Not counted

(3) Bright spots by the light passing through tears, breaks, etc in chromium mask.

- Exceed 50µm..... High bright spot
- 50µm or less Not counted

C

C

12-2-3 Test condition

- Inspector must observe the LCD screen from the normal direction under the illumination by a single 20W fluorescent lamp. The distance between the LCD screen and the inspector should be a height of 50cm above the worktable.
The vertical illuminance is 300 to 600lux (reference value).
- Bright spot should be counted under entire black screen.
- Dark spot should be counted under entire white screen.
- Input signal timing should be typical value.

D

D

(Note1) Please do not mistake a single bright spot for a bright spot connection due to Cs(supplemental capacitance) line at the center of each dot.

(Note2) If a pixel is dark partially, it connects into the number of dark spots in accordance with following rule.

- (a) $A < 1/3$: Not count. Only one of 4 dark connection is allowed.
 - (b) $1/3 \leq A < 2/3$: Considered as 0.5 dot.
 - (c) $2/3 \leq A$: Considered as 1 dot.
- (A=Dark spot size/dot size)

E

DOCUMENT CONTROL SECTION

DATE

						TITLE LQ190E1LW01 (FLC48SXC8V-11AA)	
						DRAW. NO. LD17443	
						CUST.	
EDIT	DATE	DESIG.	CHECK	APPR.	DESCRIPTION		
DESIG.			CHECK		SHARP CORPORATION		
						21/	

F

13. ENVIRONMENTAL SPECIFICATIONS

Table 13-1 show the environmental specifications.

Table 13-1 Environmental specifications

Item	Condition		Remark
Temperature	Operation	0~55°C	Temperature on surface of LCD panel (display area.)
	Storage	-20~60°C	
Humidity	Operation	20~85%RH	Maximum wet-bulb temperature should not exceed 29°C. No condensation.
	Storage	5~85%RH	
Vibration	Non-operation	10~500Hz, 1octave/ 20minute, 19.6m/s ² (2G), 1.5mm max, 1hour each X, Yand Z directions.	For single module without package.
Shock *1	Non-operation	294m/s ² (30G), 6ms, 1time each ±X, ±Y and ±Z directions.	

NOTE: Table 13-2 and Figure 13-1 show the shock resistance standard when module is packaged.

Table 13-2 Shock resistance standard when module is packaged

Dropping location	Dropping height	Count
A~J	60cm	1 time

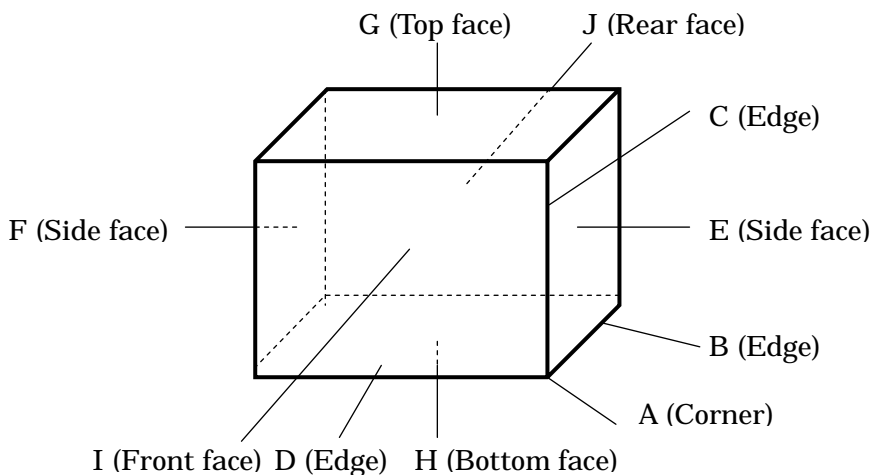

Figure 13-1 Direction to apply shock to package

DOCUMENT CONTROL SECTION

DATE

						TITLE	LQ190E1LW01 (FLC48SXC8V-11AA)	
						DRAW. NO.	LD17443	CUST.
EDIT	DATE	DESIG.	CHECK	APPR.	DESCRIPTION	SHARP CORPORATION		22/
DESIG.			CHECK		APPR.			

14. INDICATIONS

This module has the following indications.

A

- (1) Product name : **LCD unit**
- (2) SHARP Model Number : LQ190E1LW01
- (3) Model Number : FLC48SXC8V-11AA
- (4) Manufacturing Number : **5 6 0 0 0 0 1**

B

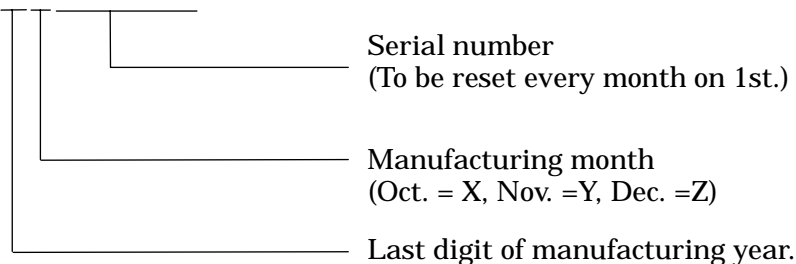

A

B

- (5) Version number : **01A** (Example)
-1st 2 digits "01" means operational version.
-3rd alphabet means functional version.

(6) Manufacturer Country Name :

C

(7) Company Name : SHARP CORPPRATION

(8) Disposal method of cold-cathode tubes.

(9) Caution when changing cold-cathode tubes.

C

D

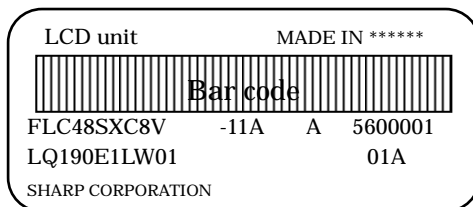

Figure 14-1 Product Label (Example)

D

15. PACKAGING

15-1 Packing specifications

- (1) 5 LCD modules/1package.
- (2) Weight : approximately 14kg /1package.
- ②(3) Outline dimensions: 499mm (W)x 250mm (D)x 464mm (H)

15-2 Packing method

Figure 15-2 show the packing method.

E

DOCUMENT CONTROL SECTION

DATE

						TITLE	LQ190E1LW01 (FLC48SXC8V-11AA)	
						DRAW. NO.	LD17443	CUST.
07	20050420					Model name and Company Name was changed		
02	20040602					Correction of packing box size.		
EDIT	DATE	DESIG.	CHECK	APPR.		DESCRIPTION	SHARP CORPORATION	23/
	DESIG.		CHECK			APPR.		

F

A

B

C

D

A

B

C

D

E

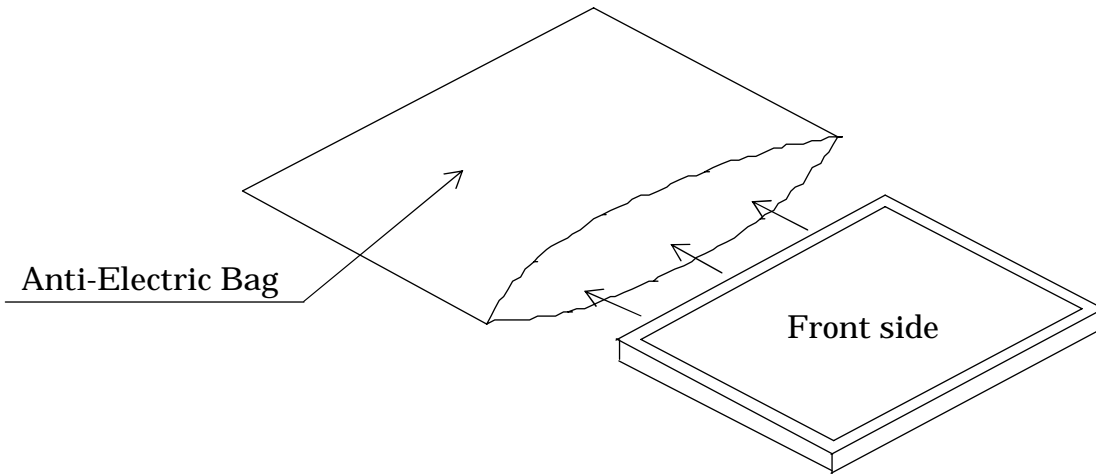
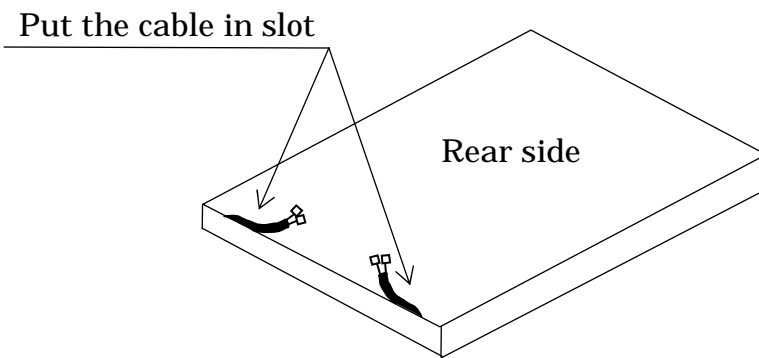
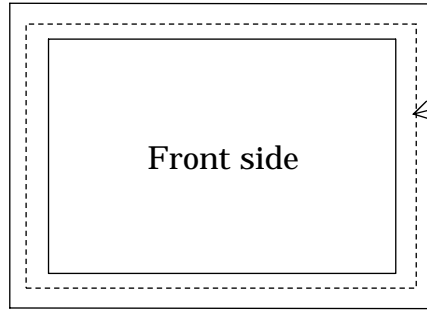

Fig.15-2 (a) Packaging Method

DATE	DOCUMENT CONTROL SECTION				

						TITLE	LQ190E1LW01 (FLC48SXC8V-11AA)	
						DRAW. NO.	LD17443	CUST.
EDIT	DATE	DESIG.	CHECK	APPR.		DESCRIPTION	SHARP CORPORATION	24 /
DESIG.			CHECK			APPR.		

A

B

C

D

A

B

C

D

E

F

①

Partition Box

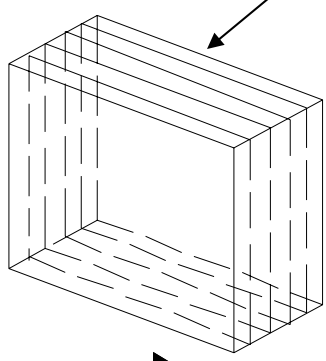

②

Anti-
Electrostatic bag

LCD Unit

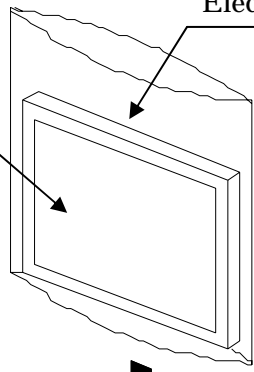

③

Holder

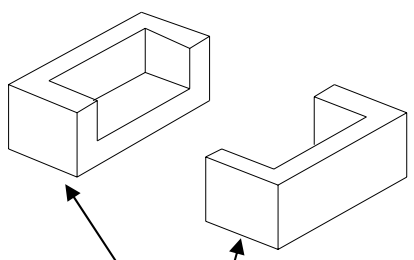

④

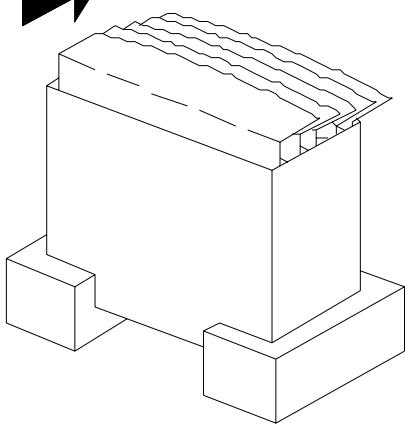
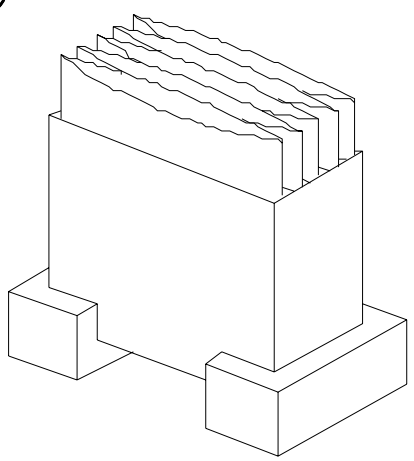

●Cautious●

Do not to put Anti-electrostatic bag
in the partition box.

The bending direction should
be arranged.

DOCUMENT CONTROL SECTION
DATE

					TITLE	LQ190E1LW01 (FLC48SXC8V-11AA)	
					DRAW. NO.	LD17443	CUST.
EDIT	DATE	DESIG.	CHECK	APPR.	DESCRIPTION		
DESIG.			CHECK	APPR.	SHARP CORPORATION		25 /

A

B

C

D

A

B

C

D

E

F

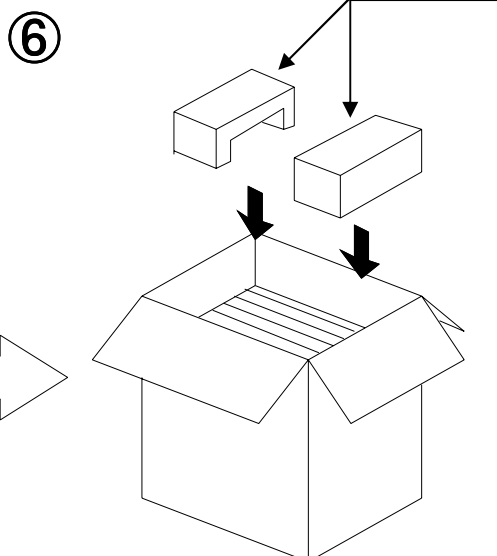
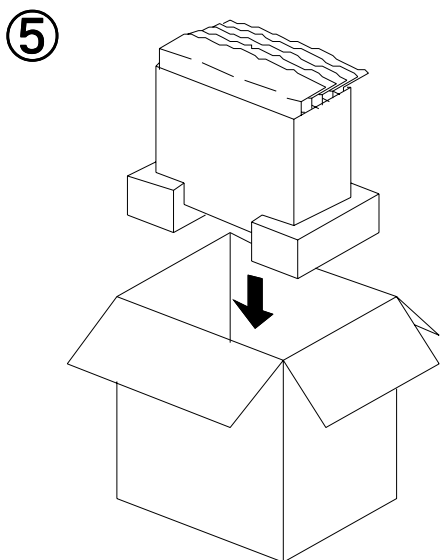

The Front side of LCD units should be faced to the direction of the making on carton box.

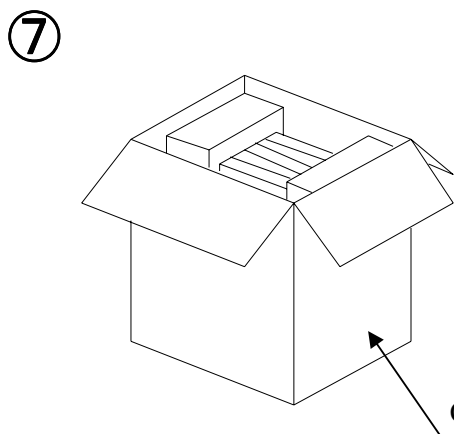

Carton Box

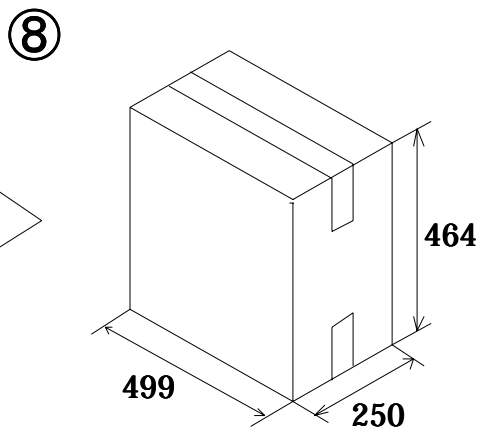

Sample of carton label

型 格 (TYPE)	FLC48SXC8V	-11A	A	数 量 (QTY.)	5
図 番 (DRG. No.)	LQ190E1LW01	**		版 数 (Rev. No.)	01A
	5600001	Bar code			
	5600002				
	5600003				
	5600004				
	5600005				

Fig.15-2 (b) Packaging Method

DOCUMENT CONTROL SECTION

DATE

					TITLE		LQ190E1LW01 (FLC48SXC8V-11AA)	
					DRAW. NO.			CUST.
07					20050420		Model name was changed.	
					LD17443			
EDIT	DATE	DESIG.	CHECK	APPR.	DESCRIPTION			SHARP CORPORATION
DESIG.			CHECK		APPR.			26 /

A

B

C

D

A

B

C

D

E

F

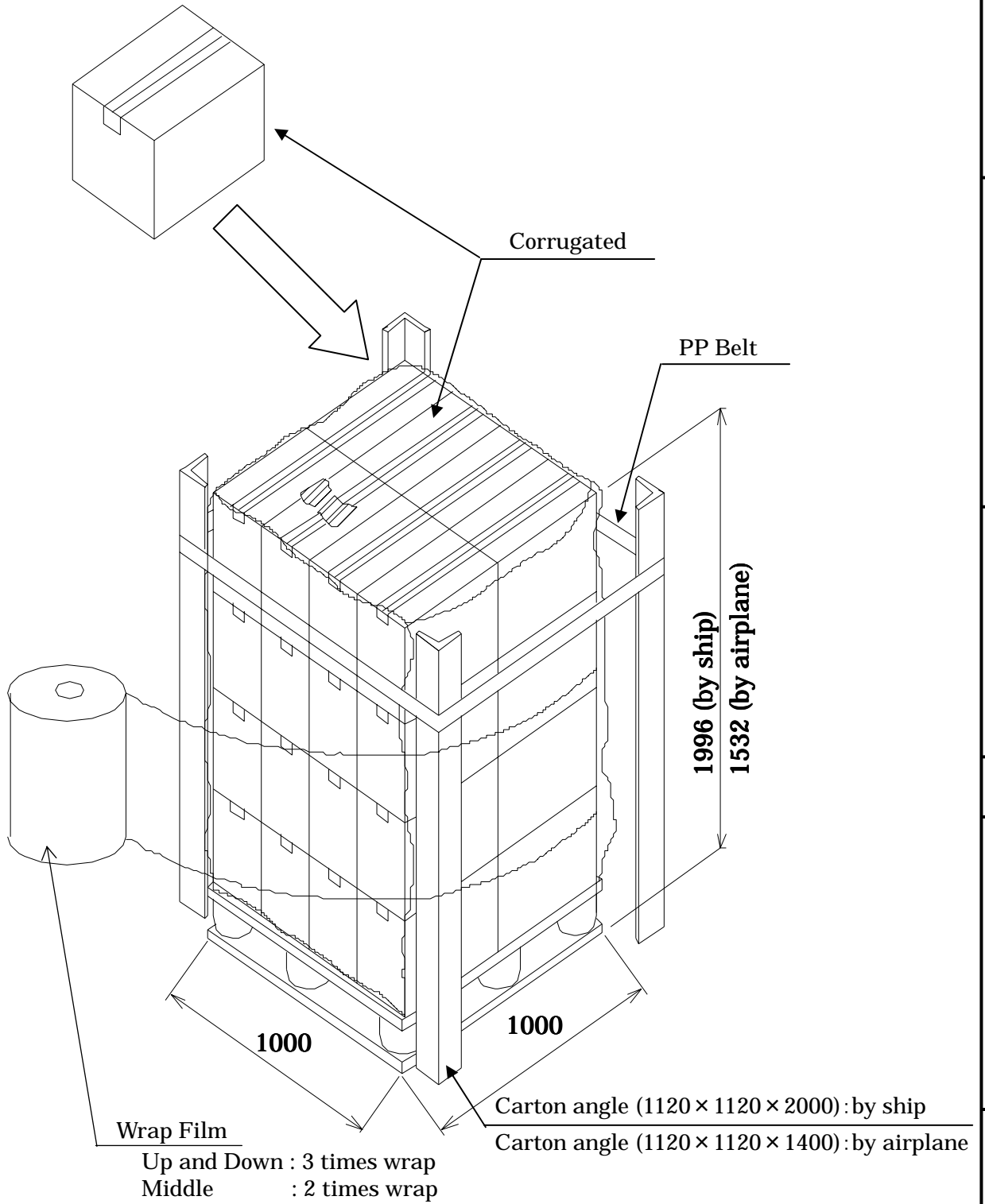

Note:1) 8 boxes × 4 layers (maximum 32 boxes) : by ship
8 boxes × 3 layers (maximum 24 boxes) : by airplane
Note:2) This drawing shows marine transportation specification.

Fig.15-2 (c) Packaging Method

DOCUMENT CONTROL SECTION
DATE

						TITLE		LQ190E1LW01 (FLC48SXC8V-11AA)	
						DRAW. NO.		LD17443	
								CUST.	
EDIT	DATE	DESIG.	CHECK	APPR.	DESCRIPTION				
DESIG.			CHECK		SHARP CORPORATION				
								27 /	

A

A

Cushioning material

Corrugated carton (A)
with LCD modules

B

B

602
(580)

Corrugated fiberboard shipping container (B)

446
(430)

646
(630)

C

C

Note 1) The carton (A) should be placed in the middle of the container (B) with enough cushioning materials.

Note2) The figures in () show inside measurements of the container (B).

Figure.15-2 (d) Packing method

D

D

DOCUMENT CONTROL SECTION

DATE

E

F

						TITLE	LQ190E1LW01 (FLC48SXC8V-11AA)	
						DRAW. NO.	LD17443	CUST.
EDIT	DATE	DESIG.	CHECK	APPR.	DESCRIPTION	SHARP CORPORATION		28 /
	DESIG.		CHECK		APPR.			

16.WARRANTY

The warranty period is one year after shipping. Products which fail during this period are repaired or replaced without charge, unless the failure is caused by user.

17.PRECAUTIONS

Adhere to the following precautions to use this LCD module properly.

(1) Fail safe design

LCD module has an inherent chance of failure. Customers must protect against injury, damage or loss from such failures by incorporating safety design measures into your facility and equipment such as redundancy, fire protection, and prevention of over-current levels and other abnormal operating conditions.

(2) Handling of LCD panel

① Do not apply any strong mechanical shock to the LCD panel.

Since the LCD panel is made of glass, excessive shock may damage the panel or cause a malfunction.

② Do not press hard on the LCD panel surface.

In the LCD panel, the gap between two glass plates is kept perfectly even to maintain display properties and reliability. The hard pressure on the LCD panel may cause the following problems. If the pressure is over 2kg/cm², the problem don't return to normal condition.

- ① Ununiformity of color
- ② Disorder of orientation of liquid crystal

Problem ① returns to normal condition after a while. Problem ② returns to normal condition by turning the power off and turning on again. However these operations should be avoided to insure reliability.

③ Do not scratch the polarizer film on the LCD panel surface.

- Do not press or rub the display surface with a hard tool, tweezers, etc.
- For handling, use cotton or conductive gloves so that the display surface is not soiled.
- If dust or dirt soils the display surface, clean it as follows with a soft cloth (deerskin, etc.)

[Dust] Wipe off with a soft cloth. (do not rub.)

[Dirt] Apply clear water to a soft cloth and squeeze hard out of water drops, then lightly wipe off the specified parts. Only if the dirt is hardly wiped off, use isopropyl alcohol or ethanol.

Be careful not to splash the water or the solvents on the edge of polarizer and in the LCD unit.

The polarizer possibly exfoliates due to the solvent and water penetrated between the polarizer and the LCD panel.

Do not use unspecified solvent such as ketone (acetone, etc.) and aromatics (xylene, toluene, etc.)

DATE DOCUMENT CONTROL SECTION

						TITLE	LQ190E1LW01 (FLC48SXC8V-11AA)	
						DRAW. NO.	LD17443	CUST.
EDIT	DATE	DESIG.	CHECK	APPR.	DESCRIPTION	SHARP CORPORATION		29 /
DESIG.			CHECK		APPR.			

A

(Caution) Be careful not to allow the water or solvent to enter the module.

- If saliva or water drops are left for a long period of time, the part may become deformed or discolored.

Wipe off immediately in the same way as for dirt.

- Do not allow oil to adhere to the module since excessive oil is hard to clean.

④ Do not place or contact objects on the display surface for a long period of time.

This may make some parts of the LCD module distorted and the quality of display may deteriorate.

B

(3) Handling of LCD module

① Do not pull the cold-cathode tube cable strongly.

If the cable is pulled with the strength of 2kg or more, the cable may be damaged or may lose reliability.

② Assemble the module into user's system in a dust free environment.

Conductive foreign matter adheres to the module may cause failures.

③ Take anti-electrostatic measures for assembling the module.

Since the LCD module contains CMOS-ICs, the following points should be observed.

- For assembling the module, operator should be grounded and wear cotton or conductive gloves.
- Floor of work area and work table to assemble the LCD module should be covered with electrostatic shielding in order to discharge static electricity via an earth wire.
- If necessary, ground operation tools (soldering iron, radio pliers, tweezers, etc.).
- Do not take the module out of the conductive bag until the module is assembled.
- Do not assemble the module under low humidity (50%RH or less).

C

④ Do not pull the connecting cable on the rear face of the LCD module strongly.

⑤ Do not disassemble or remodel the LCD module.

Disassembly or remodeling of the LCD module may result in malfunctions or deterioration of the display quality and reliability.

D

(4) Precautions in regards of operating the LCD module

① Adhere to the specified power supply sequence.

If not followed, the CMOS-IC may cause a latch-up, or DC voltage may be applied to the liquid crystal, which cause a failure or serious deterioration in display quality.

② Do not operate the LCD module when condensation occurs.

If the LCD module is operated when condensation is on the terminals of the LCD panel, the terminals cause electrochemical reaction, and may reach disconnection. Condensation easily occurs especially when the module is moved from cold environment to warm environment.

A

B

C

D

E

DOCUMENT CONTROL SECTION

DATE

						TITLE		LQ190E1LW01	
								(FLC48SXC8V-11AA)	
						DRAW. NO.		LD17443	
								CUST.	
EDIT	DATE	DESIG.	CHECK	APPR.	DESCRIPTION				
DESIG.			CHECK		SHARP CORPORATION				
								30 /	

F

A

A

③ The following troubles occur when the LCD module is not used under recommended temperature.

- Operation under high temperature(>50°C): Display colors shift to blue.
- Storage under high temperature(>60°C): The polarizer film deteriorates and contrast decreases.
- Operation under low temperature(< 0°C): The response speed decreases considerably.
- Storage under low temperature(<-20°C): The liquid crystal may solidify and become damaged.

B

B

④ Be sure to input the control signals at the correct timing.

If control signals (DCLK, ENAB) are not input, or if the timing is out of the specified timing, DC voltage may be applied to the liquid crystal and, as a result, cause image sticking or deterioration of contrast.

(5) Precautions in regards of designing module mounting

C

C

① Excessive force should not be applied to the screen or the rear side of the LCD module.

Excessive pressure on the screen caused by the installation of the LCD module may deteriorate display quality and reliability.
Brightness uniformity and the reliability of CCFL may decrease if the pressure is applied to the backlight module.

② Avoid twisting and bending the LCD module.

Excessive twist and bend may damage display quality and reliability.

③ Avoid extending the power cable between the LCD module and inverter.

This may cause the backlight to flicker or not to light.

④ Keep the backlight cable apart from the metal enclosure of the LCD module.

When frequency current for backlight driving leak to the metal enclosure, the desired brightness may not be assured.

D

D

⑤ When mounting LCD module with M3 screws (x4), tighten the screws with torque 3.5kgf.

(6) Storage method

① Do not store the LCD module in an atmosphere of organic solvent or corrosive gas.

In an organic solvent atmosphere, the polarizer film discolors and display quality deteriorates.
In a corrosive gas environment, various parts of the module may corrode or deteriorate.

② Store the LCD module in a SHARP package.

At storing, SHARP packages can be stacked up to 3 boxes.
The LCD module is in an anti-static bag. Keep the module in that status.

E

DOCUMENT CONTROL SECTION

DATE

						TITLE LQ190E1LW01 (FLC48SXC8V-11AA)	
						DRAW. NO. LD17443	
						CUST.	
07	20050420				Company Name was changed		
EDIT	DATE	DESIG.	CHECK	APPR.	DESCRIPTION		
					SHARP CORPORATION		
			CHECK				31 /

F

A

③ The LCD module is recommended to be stored in humidity controlled, cool and dark locations.

Recommended storage environment

- Place : Dark (avoid direct sunlight)
- Temperature : 10~35°C
- Humidity : 50~60%RH

Note) If the module is left in an environment of 60°C and above for a long period of time, optical characteristics may deteriorate.

A

(7) Disposal Method

① LCD module

The components of this LCD module can be grouped into metal, resin, glass and so on. As the backlight contains CCFL which includes mercury, it must be disposed according to the local ordinance or regulations.

② Package

All the packages are made of recyclable papers except the anti-ESD bag.

B

B

(8) CAUTION IN DESIGNING INVERTER

Fluorescent lamps driven by high voltage are included in this LCD module. Please stand to the instructions below when designing inverter that lights the fluorescent lamps. Otherwise it may lead to FATAL FAILURE, such as SMOKING or FIRING.

C

C

① **APPLY PROTECTIVE CIRCUIT** in preparation for lamp breaking, wire breaking and short circuit. The protective circuit should also detect half open circuit and wire breaking in narrow gap etc.. Otherwise it may lead to fatal failure.

② **KEEP ENOUGH CURRENT CAPACITY** of inverter output for leakage current, which leaks from lamps and wire to surrounding metal material. Usually output current of about 1.5 times as same as the lamp current is necessary. But it sometimes varies due to characteristics of the inverter itself. So before determining design, please check characteristics of the inverter by connecting it to the LCD module.

D

D

③ **KEEP ENOUGH TEMPERATURE MARGIN** for each parts mounted on inverter. Temperature of the parts becomes higher when they are mounted in the final products due to heating inside. The temperature of each parts **MUST NOT** increase over the guaranteed temperature.

E

DOCUMENT CONTROL SECTION

DATE

F

						TITLE	LQ190E1LW01 (FLC48SXC8V-11AA)	
						DRAW. NO.	LD17443	CUST.
EDIT	DATE	DESIG.	CHECK	APPR.	DESCRIPTION	SHARP CORPORATION		32 /
DESIG.			CHECK		APPR.			

(8) Return method of the LCD module requested for repair or analysis of the problem

- When returning the LCD modules, adhere to the following procedures not to damage the LCD panel or the backlight cables. (Fig. 17-1(a)~(b))
When the LCD module is returned without following the specified packaging procedures, SHARP will not take responsibility for the damages caused by the failure of the packaging method.
- Please be cautious not to put fingerprints or other stains on the display by wearing a glove or fingerstall when managing LCD module modules, including faulty modules that require to be returned .

(1) Attach protective sheet.

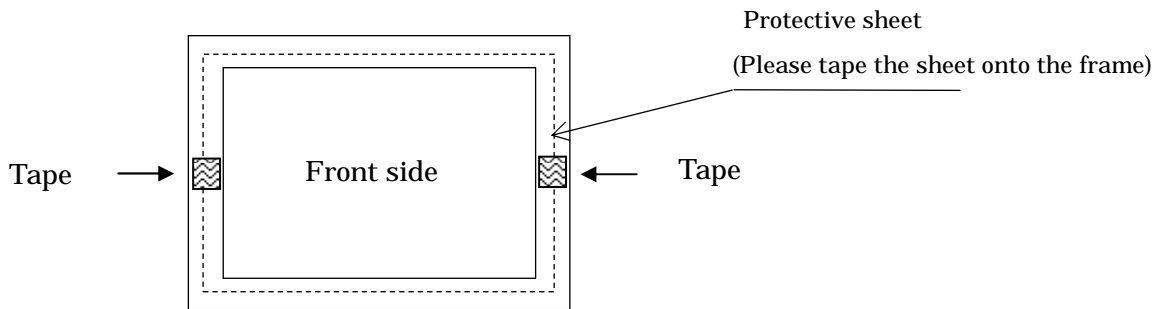

(2) Put the backlight cables in slots.

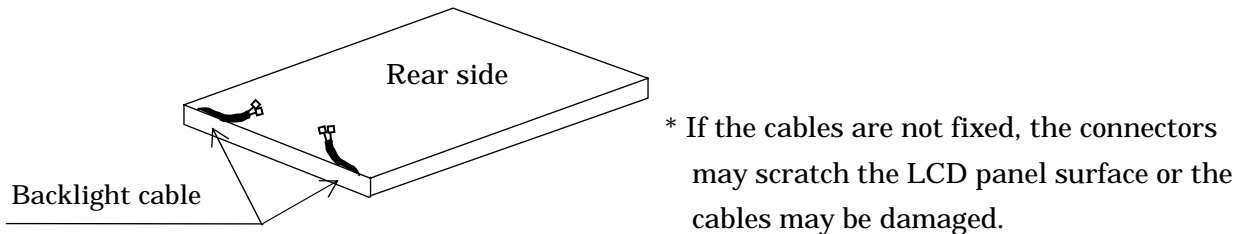

(3) Put the LCD module into the anti-electrostatic bag
(Please do not use torn anti-electrostatic bags)

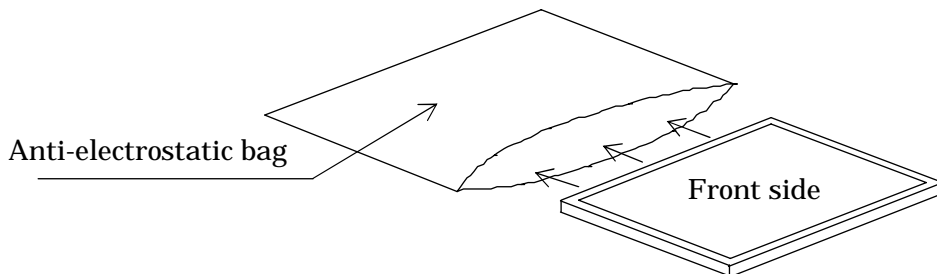

Fig. 17-1(a) Packaging method

DOCUMENT CONTROL SECTION

DATE

						TITLE LQ190E1LW01 (FLC48SXC8V-11AA)	
						DRAW. NO. LD17443	
						CUST.	
07	20050420				Company Name was changed		
EDIT	DATE	DESIG.	CHECK	APPR.	DESCRIPTION		
DESIG.			CHECK		SHARP CORPORATION		33 /

(4) Storage into the carton box

- When using the carton box manufactured by SHARP
(Please use carton boxes and arrowheads that are not collapsed)

A

A

B

B

C

C

D

D

E

①

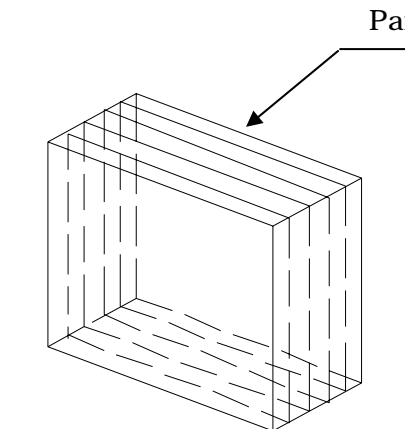

Partition Box

②

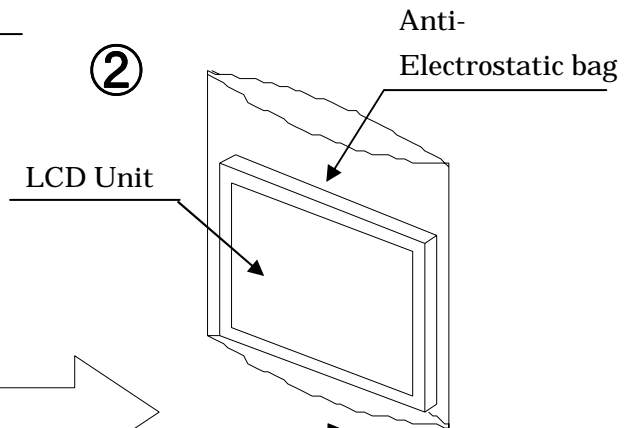

LCD Unit

Anti-
Electrostatic bag

③

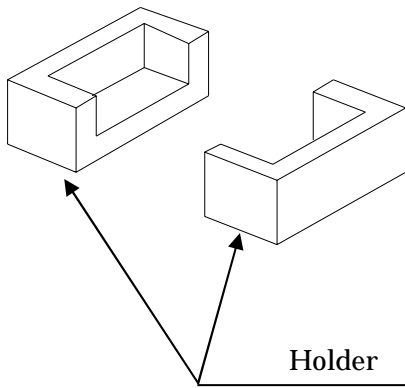

Holder

④

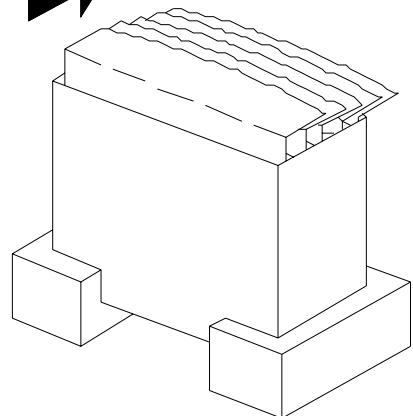
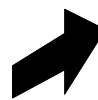
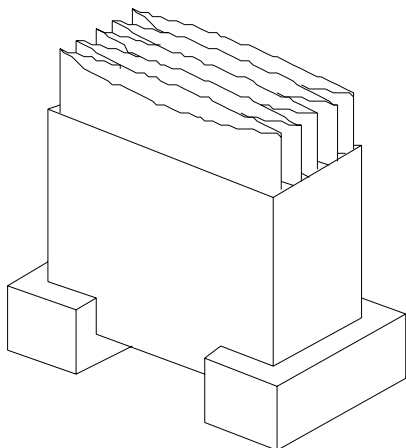

●Cautious●

Do not to put Anti-electrostatic bag
in the partition box.

The bending direction should
be arranged.

DOCUMENT CONTROL SECTION

DATE

						TITLE LQ190E1LW01 (FLC48SXC8V-11AA)	
						DRAW. NO. LD17443	
07 20050420						CUST.	
Company Name was changed							
EDIT	DATE	DESIG.	CHECK	APPR.	DESCRIPTION		
DESIG.			CHECK		SHARP CORPORATION		
						34/	

A

B

C

D

A

B

C

D

E

F

⑤

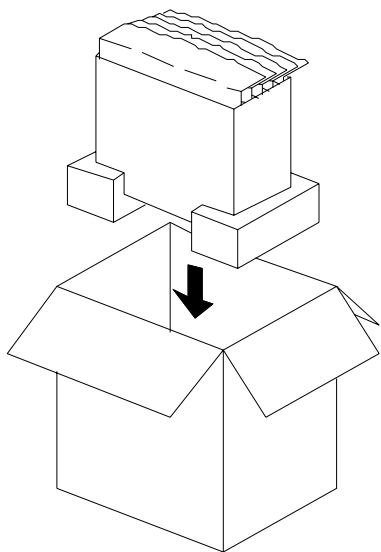

⑥

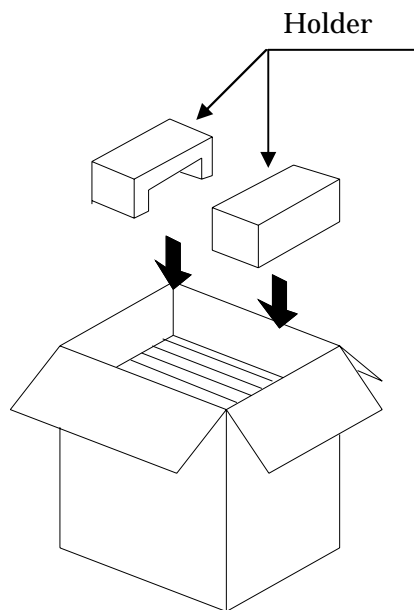

The Front side of LCD units should be faced to the direction of the making on carton box.

⑦

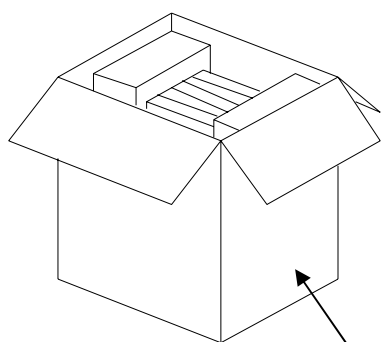

⑧

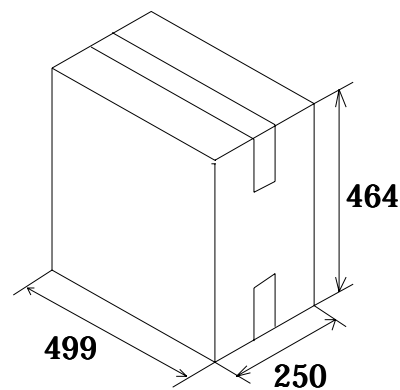

The arrowheads are shown on the holders.

Fig. 17-1(b) Packaging method

- When not using the carton box manufactured by SHARP
Please pack the LCD modules one by one and make sure not to damage the LCD modules when transporting.

DOCUMENT CONTROL SECTION
DATE

					TITLE	LQ190E1LW01 (FLC48SXC8V-11AA)	
					DRAW. NO.	LD17443	CUST.
07	20050420				Company Name was changed		
EDIT	DATE	DESIG.	CHECK	APPR.	DESCRIPTION		
DESIG.			CHECK		SHARP CORPORATION		35 /

(9) Others

① **If the LCD panel is damaged, do not inhale and do not swallow the liquid crystal.**
 If the liquid crystal adhere to the body or cloths, wash it off with soap immediately.
 Follow regular precautions for electronic components.

② **Flux residue on the printed circuit board is harmless to the quality and reliability of LCD module.**
 SHARP has adopted non-wash technology on module assembly process.

18. PRECAUTIONS FOR USE

This Product is designed, developed and manufactured as contemplated for general use, including without limitation, general office use, personal use, household use, and ordinary industrial use, but is not designed, developed and manufactured as contemplated for use accompanying fatal risks or dangers that, unless extremely high safety is secured, could lead directly to death, personal injury, severe physical damage or other loss (hereinafter "High Safety Required Use"), including without limitation, nuclear reaction control in nuclear facility, aircraft flight control, air traffic control, mass transport control, medical life support system, missile launch control in weapon system. If customer's product possibly falls under the category of High Safety Required Use, please consult with our sales representatives in charge before such use. In addition, SHARP shall not be liable against the Customer and/or any third party for any claims or damages arising in connection with the High Safety Required Use of the Product without permission.

19. MISCELLANEOUS

Specifications of the TFT-LCD panel and other components used in the LCD module are subject to change. Both parties shall discuss together before change.
 If any doubt is raised in the content of the specifications, both parties shall discuss and make best effort for the agreement.

DOCUMENT CONTROL SECTION
DATE

						TITLE LQ190E1LW01 (FLC48SXC8V-11AA)	
						DRAW. NO. LD17443	
						CUST.	
07	20050420				Company Name was changed		
EDIT	DATE	DESIG.	CHECK	APPR.	DESCRIPTION		
	DESIG.		CHECK		SHARP CORPORATION		36 /

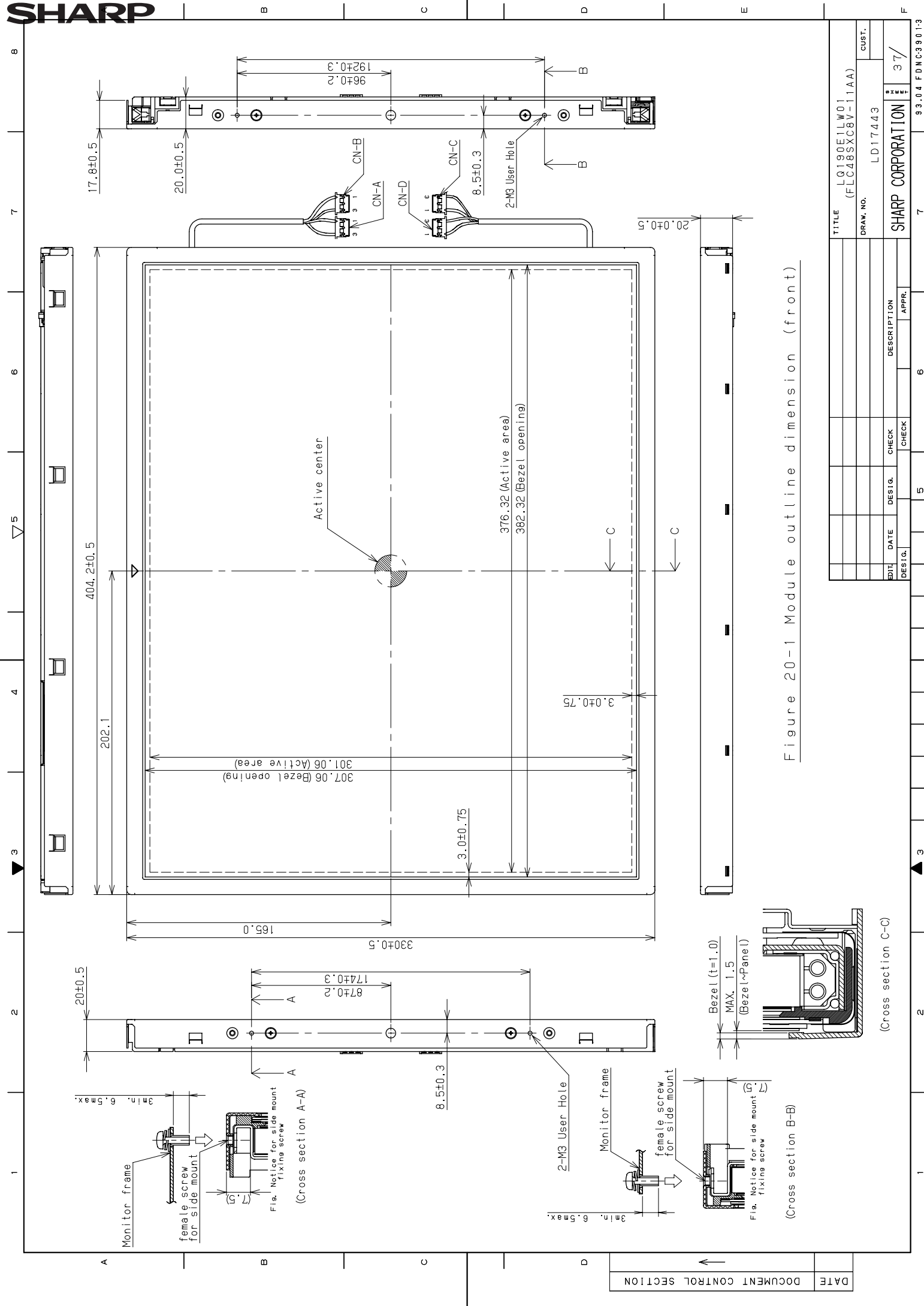

Figure 20-1 Module outline dimension (front)

TITLE	LQ190E1LW01 (FLC48SXCBV-11AA)
DRAW. NO.	LD17443
CUST.	
DATE	
REV.	37/
SHARP CORPORATION	

EDIT. DESIG.	DATE	DESIG.	CHECK	DESCRIPTION	APPR.

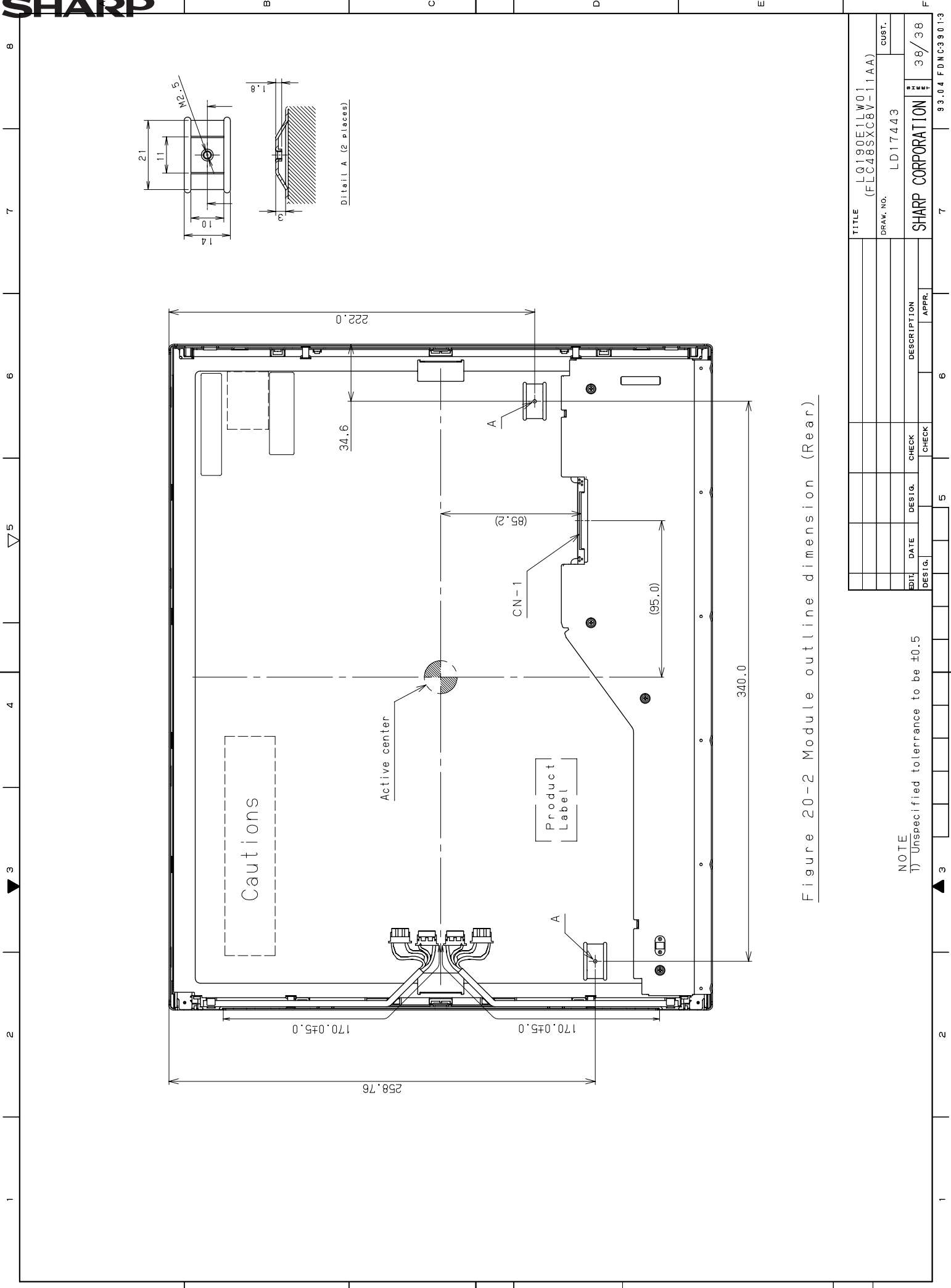

Figure 20-2 Module outline dimension (Rear)

NOTE
1) Unspecified tolerance to be ± 0.5

TITLE		LQ190E1LW01 (FLC48SXC8V-11AA)	
DRAW. NO.		LD17443	
CUST.			
EDIT	DATE	DESIG.	CHECK
DESIG.			APPR.
DESCRIPTION		SHARP CORPORATION	
38/38		93.04 FDN C39 013	

DATE	
DOCUMENT CONTROL SECTION	

SPECIFICATIONS ARE SUBJECT TO CHANGE WITHOUT NOTICE.

Suggested applications (if any) are for standard use; See Important Restrictions for limitations on special applications. See Limited Warranty for SHARP's product warranty. The Limited Warranty is in lieu, and exclusive of, all other warranties, express or implied. ALL EXPRESS AND IMPLIED WARRANTIES, INCLUDING THE WARRANTIES OF MERCHANTABILITY, FITNESS FOR USE AND FITNESS FOR A PARTICULAR PURPOSE, ARE SPECIFICALLY EXCLUDED. In no event will SHARP be liable, or in any way responsible, for any incidental or consequential economic or property damage.

SHARP®

NORTH AMERICA

SHARP Microelectronics of the Americas
5700 NW Pacific Rim Blvd.
Camas, WA 98607, U.S.A.
Phone: (1) 360-834-2500
Fax: (1) 360-834-8903
Fast Info: (1) 800-833-9437
www.sharpsma.com

EUROPE

SHARP Microelectronics Europe
Division of Sharp Electronics (Europe) GmbH
Sonninstrasse 3
20097 Hamburg, Germany
Phone: (49) 40-2376-2286
Fax: (49) 40-2376-2232
www.sharpsme.com

JAPAN

SHARP Corporation
Electronic Components & Devices
22-22 Nagaike-cho, Abeno-Ku
Osaka 545-8522, Japan
Phone: (81) 6-6621-1221
Fax: (81) 6117-725300/6117-725301
www.sharp-world.com

TAIWAN

SHARP Electronic Components
(Taiwan) Corporation
8F-A, No. 16, Sec. 4, Nanking E. Rd.
Taipei, Taiwan, Republic of China
Phone: (886) 2-2577-7341
Fax: (886) 2-2577-7326/2-2577-7328

SINGAPORE

SHARP Electronics (Singapore) PTE., Ltd.
438A, Alexandra Road, #05-01/02
Alexandra Technopark,
Singapore 119967
Phone: (65) 271-3566
Fax: (65) 271-3855

KOREA

SHARP Electronic Components
(Korea) Corporation
RM 501 Geosung B/D, 541
Dohwa-dong, Mapo-ku
Seoul 121-701, Korea
Phone: (82) 2-711-5813 ~ 8
Fax: (82) 2-711-5819

CHINA

SHARP Microelectronics of China
(Shanghai) Co., Ltd.
28 Xin Jin Qiao Road King Tower 16F
Pudong Shanghai, 201206 P.R. China
Phone: (86) 21-5854-7710/21-5834-6056
Fax: (86) 21-5854-4340/21-5834-6057

Head Office:

No. 360, Bashen Road,
Xin Development Bldg. 22
Waigaoqiao Free Trade Zone Shanghai
200131 P.R. China
Email: smc@china.global.sharp.co.jp

HONG KONG

SHARP-ROXY (Hong Kong) Ltd.
3rd Business Division,
17/F, Admiralty Centre, Tower 1
18 Harcourt Road, Hong Kong
Phone: (852) 28229311
Fax: (852) 28660779
www.sharp.com.hk

Shenzhen Representative Office:

Room 13B1, Tower C,
Electronics Science & Technology Building
Shen Nan Zhong Road
Shenzhen, P.R. China
Phone: (86) 755-3273731
Fax: (86) 755-3273735

Mouser Electronics

Authorized Distributor

Click to View Pricing, Inventory, Delivery & Lifecycle Information:

[Sharp Microelectronics:](#)

[LQ190E1LW01](#)